

Absolute encoders - parallel

Shaft with clamping or synchro flange

Optical singleturn encoders 13 bit

GA240, GA241 - parallel



GA240 with clamping flange

Features

- Encoder singleturn / parallel
- Optical sensing
- Resolution: 13 bit
- Clamping or synchro flange
- Short-circuit proof push-pull outputs
- Output release by enable signal
- Permanent check of code continuity

Technical data - electrical ratings

Voltage supply	10...30 VDC
Reverse polarity protection	Yes
Consumption w/o load	≤60 mA (24 VDC)
Initializing time (typ.)	20 ms after power on
Interface	13 parallel outputs
Function	Singleturn
Steps per turn	8192 / 13 bit
Absolute accuracy	±0.025 °
Sensing method	Optical
Code	Gray or binary
Code sequence	CW/CCW coded by connection
Inputs	Control signals UP/ <u>DOWN</u> and zero <u>STORE</u> <u>ENABLE</u>
Output circuit	Push-pull short-circuit proof
Interference immunity	DIN EN 61000-6-2
Emitted interference	DIN EN 61000-6-4
Diagnostic functions	Self-diagnosis Code continuity check
Approval	UL approval / E63076

Technical data - mechanical design

Housing	ø58 mm
Protection DIN EN 60529	IP 54 without shaft seal IP 65 with shaft seal
Operating speed	≤10000 rpm (mechanical) ≤6000 rpm (electric)
Starting torque	≤0.015 Nm IP 54 ≤0.03 Nm IP 65
Rotor moment of inertia	14.5 gcm ²
Admitted shaft load	≤20 N axial ≤40 N radial
Materials	Housing: aluminium Flange: aluminium
Operating temperature	-25...+85 °C -40...+85 °C (optional)
Relative humidity	95 % non-condensing
Resistance	DIN EN 60068-2-6 Vibration 10 g, 16-2000 Hz DIN EN 60068-2-27 Shock 200 g, 6 ms
Weight approx.	250 g
Connection	Connector M27, 21-pin Cable 1 m

GA240

Shaft	ø10 mm
Flange	Clamping flange

GA241

Shaft	ø6 mm
Flange	Synchro flange

Absolute encoders - parallel

Shaft with clamping or synchro flange

Optical singleturn encoders 13 bit

GA240, GA241 - parallel

Part number

Clamping flange

GA240. **02**

Connection

- C0 Connector M27, 21-pin, axial
- C1 Connector M27, 21-pin, radial
- 51 Cable 21-core, 1 m, axial
- 61 Cable 21-core, 1 m, radial

Voltage supply / signals

- 10 10...30 VDC / gray code push-pull
- 12 10...30 VDC / binary code push-pull

Flange / Shaft

- 0 Clamping flange / ø10 mm IP 54
- A Clamping flange / ø10 mm IP 65

Synchro flange

GA241. **02**

Connection

- C0 Connector M27, 21-pin, axial
- C1 Connector M27, 21-pin, radial
- 51 Cable 21-core, 1 m, axial
- 61 Cable 21-core, 1 m, radial

Voltage supply / signals

- 10 10...30 VDC / gray code push-pull
- 12 10...30 VDC / binary code push-pull

Flange / Shaft

- 1 Synchro flange / ø6 mm IP 54
- B Synchro flange / ø6 mm IP 65

Accessories

Connectors and cables

- Z 132.001 Female connector M27, 21-pin, less cable
- Z 132.003 Female connector M27, 21-pin, 2 m cable
- Z 132.005 Female connector M27, 21-pin, 5 m cable
- Z 132.007 Female connector M27, 21-pin, 10 m cable

Mounting accessories for GA240

- Z 119.006 Eccentric fixing, single
- Z 119.013 Adaptor plate for clamping flange for modification into synchro flange
- Z 119.017 Mounting angle for clamping flange
- Z 119.025 Adaptor plate for clamping flange, mounting by eccentric fixings (order separately)

Mounting accessories for GA241

- Z 119.006 Eccentric fixing, single
- Z 119.015 Mounting adaptor for synchro flange
- Z 119.035 Bearing flange for encoders with synchro flange

Absolute encoders - parallel

Shaft with clamping or synchro flange

Optical singleturn encoders 13 bit

GA240, GA241 - parallel

Terminal significance	
UB	Encoder voltage supply.
GND	Encoder ground connection relating to UB.
Outputs D0-D12	13 parallel output signals.
$\overline{\text{DATAVALID}}$	Diagnostic output. An error warning is given at level Low. Important: Interferences must be filtered by the downstream electronics.
Zero setting	Input for setting a zero point anywhere within the programmed encoder resolution. The zero setting operation is triggered by a High impulse and has to be in line with the selected direction of rotation ($\overline{\text{UP/DOWN}}$). Connect to GND after setting operation for maximum interference immunity. Impulse duration ≥ 100 ms.
$\overline{\text{UP/DOWN}}$	$\overline{\text{UP/DOWN}}$ counting direction input. This input is standard on High. $\overline{\text{UP/DOWN}}$ means ascending output data with clockwise shaft rotation when looking at flange. $\overline{\text{UP/DOWN}}$ -Low means ascending values with counterclockwise shaft rotation when looking at flange.
ENABLE	Input for activating the output drivers that are triggered by input level Low. Upon being on High (or less potential) the output drivers switch to high-impedance (Tristate).
STORE	Input for output data storage. Upon a Low input level the encoder data are stored in the intermediate memory. Upon being on High (or less potential) the current encoder position data are switched to the output drivers. This line must be applied for reliable data readout in binary code.

Terminal assignment		
Connector	Core colour	Assignment
Pin 1	violet	Output D0
Pin 2	white/brown	Output D1
Pin 3	white/green	Output D2
Pin 4	white/yellow	Output D3
Pin 5	white/grey	Output D4
Pin 6	white/pink	Output D5
Pin 7	white/blue	Output D6
Pin 8	white/red	Output D7
Pin 9	white/black	Output D8
Pin 10	brown/green	Output D9
Pin 11	brown/yellow	Output D10
Pin 12	brown/grey	Output D11
Pin 13	brown/pink	Output D12
Pin 14	green/grey	-
Pin 15	blue	GND
Pin 16	blue/yellow	$\overline{\text{DATAVALID}}$
Pin 17	brown	$\overline{\text{UP/DOWN}}$
Pin 18	pink	$\overline{\text{STORE}}$
Pin 19	red	UB
Pin 20	red/yellow	Zero setting
Pin 21	yellow	$\overline{\text{ENABLE}}$

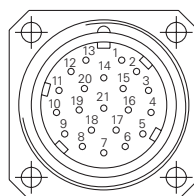

Trigger level	
Control inputs	Input circuit
Input level High	>0.7 UB
Input level Low	<0.3 UB
Input resistance	10 k Ω
Parallel outputs	Output circuit
	Push-pull circuit-proof
Output level High	>UB -3.5 V (I = -20 mA)
Output level Low	<0.5 V (I = 20 mA)
Load High	<-30 mA
Load Low	<30 mA
Tristate	<10 μ A

Absolute encoders - parallel

Shaft with clamping or synchro flange

Optical singleturn encoders 13 bit

GA240, GA241 - parallel

Dimensions

GA240 parallel clamping flange

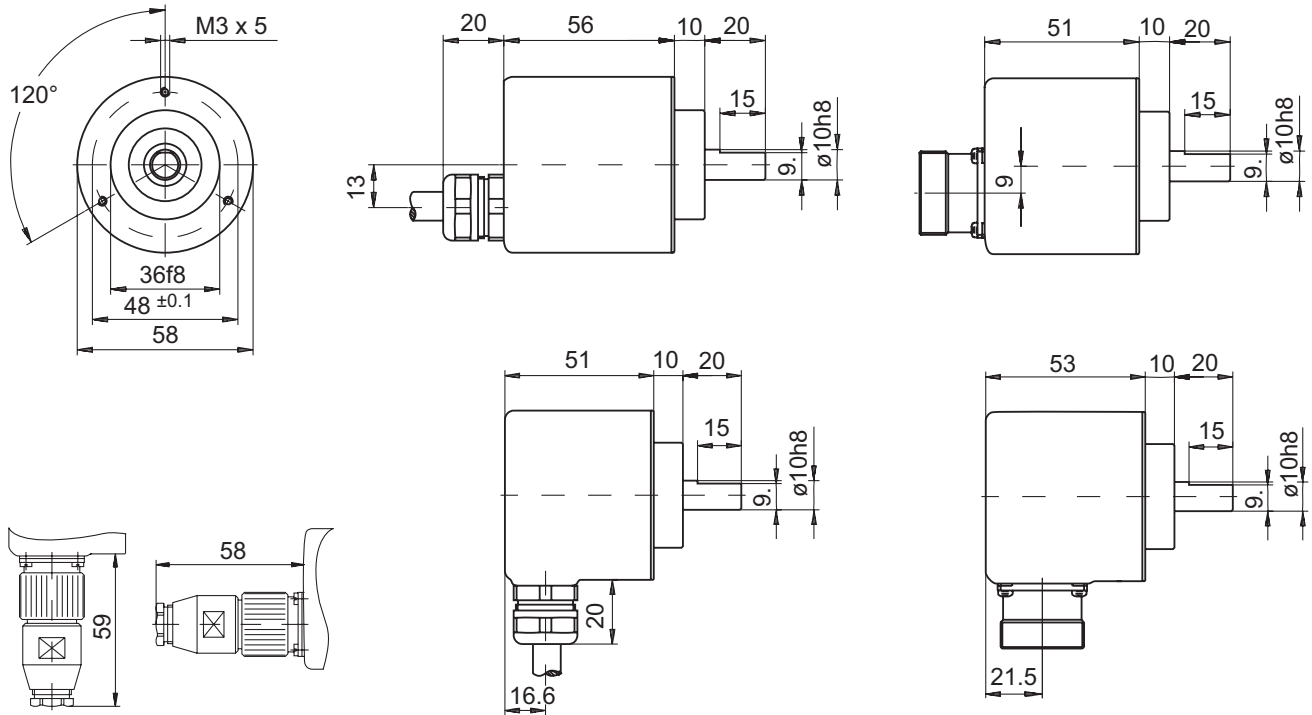

GA241 parallel synchro flange

