

Incremental encoders

Hollow shaft max. \varnothing 14 mm

Resolution 5...6000 pulses

GI331, GI333



GI331 with hollow shaft

Technical data - electrical ratings

Voltage supply	5 VDC \pm 10 % 4.75...30 VDC
Reverse polarity protection	Yes (4.75...30 VDC)
Consumption w/o load	\leq 30 mA (24 VDC) \leq 60 mA (5 VDC)
Resolution (steps/turn)	5...6000
Reference signal	Zero pulse, width 90°
Sensing method	Optical
Output frequency	\leq 150 kHz
Output signals	A 90° B, N + inverted
Output circuit	Linedriver RS422 Push-pull short-circuit proof
Interference immunity	DIN EN 61000-6-2
Emitted interference	DIN EN 61000-6-4
Approval	UL approval / E63076

Features

- Encoder with hollow shaft max. \varnothing 14 mm
- Optical sensing
- Resolution max. 6000 ppr
- Mounting by thread pin or clamping ring
- Cost-efficient mounting

Optional

- Stainless steel design GE333

Technical data - mechanical design

Housing	\varnothing 58 mm
Protection DIN EN 60529	IP 54 IP 65
Operating speed	\leq 6000 rpm
Starting torque	\leq 0.03 Nm IP 54 \leq 0.09 Nm IP 65
Rotor moment of inertia	14.5 gcm ²
Materials	Housing: aluminium Flange: aluminium
Operating temperature	-25...+100 °C (5 VDC) -25...+85 °C (24 VDC)
Relative humidity	95 % non-condensing
Resistance	DIN EN 60068-2-6 Vibration 10 g, 16-2000 Hz DIN EN 60068-2-27 Shock 200 g, 6 ms
Weight approx.	250 g
Connection	Connector M23, 12-pin Cable 1 m

GI331

Shaft \varnothing 12 mm hollow shaft

GI333

Shaft \varnothing 12 mm hollow shaft
 \varnothing 14 mm hollow shaft

Incremental encoders

Hollow shaft max. \varnothing 14 mm

Resolution 5...6000 pulses

GI331, GI333

Part number

Hollow shaft with thread pins

GI331.

See part number (pulses)

Connection

- C3 Connector M23, 12-pin, radial
- 41 Cable 1 m, radial

Voltage supply / signals

- 22 5 VDC / linedriver RS422
- 70 4.75...30 VDC / push-pull
- 72 4.75...30 VDC / linedriver RS422 (5 VDC)

Hollow shaft / torque pin

- 0 Hollow shaft \varnothing 12 mm with 2 thread pins with pin 15 mm, IP 54
- 1 Hollow shaft \varnothing 12 mm with 2 thread pins with pin 9.5 mm, IP 54
- A Hollow shaft \varnothing 12 mm with 2 thread pins without pin, IP 54

Hollow shaft with clamping ring

GI333.

See part number (pulses)

Connection

- C3 Connector M23, 12-pin, radial
- 41 Cable 1 m, radial

Voltage supply / signals

- 22 5 VDC / linedriver RS422
- 70 4.75...30 VDC / push-pull
- 72 4.75...30 VDC / linedriver RS422 (5 VDC)

Hollow shaft / torque pin

- 0 Hollow shaft \varnothing 12 mm clamping ring on housing with pin 15 mm, IP 54
- 1 Hollow shaft \varnothing 12 mm clamping ring on housing with pin 9.5 mm, IP 54
- A Hollow shaft \varnothing 12 mm clamping ring on housing without pin, IP 54
- G Hollow shaft \varnothing 12 mm clamping ring on housing with pin 15 mm, IP 65
- 4 Hollow shaft \varnothing 14 mm clamping ring on housing with pin 15 mm, IP 54
- 5 Hollow shaft \varnothing 14 mm clamping ring on housing with pin 9.5 mm, IP 54
- C Hollow shaft \varnothing 14 mm clamping ring on housing without pin, IP 54

Part number (pulses)

49 (5)	57 (128)	22 (1000)	31 (3600)
36 (10)	06 (200)	23 (1024)	34 (4096)
50 (25)	09 (250)	24 (1250)	35 (5000)
39 (50)	13 (360)	26 (1500)	48 (6000)
40 (60)	14 (400)	28 (2000)	
41 (100)	15 (500)	30 (2500)	

Other pulse numbers upon request.

Example: order key 23 = 1024 pulses.

Accessories

Connectors and cables

Z 141.001	Female connector M23, 12-pin, less cable
Z 141.003	Female connector M23, 12-pin, 2 m cable
Z 141.005	Female connector M23, 12-pin, 5 m cable
Z 141.007	Female connector M23, 12-pin, 10 m cable

Mounting accessories

Z 119.023	Spring coupling for encoders with \varnothing 58 mm housing
Z 119.024	Torque support and spring washer for encoders with 9.5 mm pin
Z 119.041	Torque support by rubber buffer element for encoders with 15 mm pin

Incremental encoders

Hollow shaft max. $\varnothing 14$ mm

Resolution 5...6000 pulses

GI331, GI333

Output signals

Clockwise rotating direction when looking at flange.

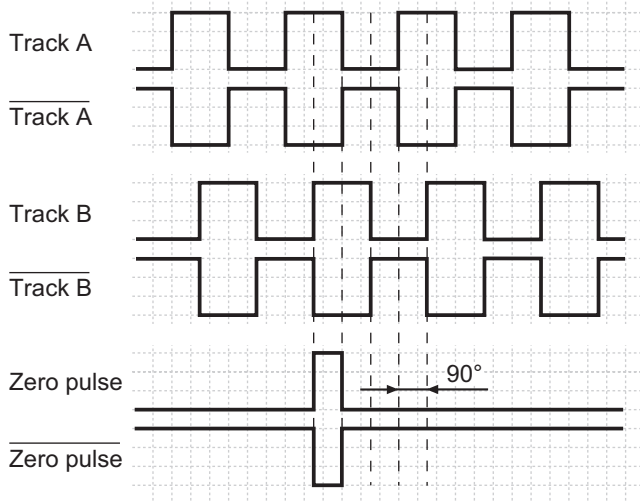

Terminal assignment

Connector	Core colour	Assignment
Pin 1	pink	Track B inv.
Pin 2	blue	UB-Sense
Pin 3	red	Track N (zero pulse)
Pin 4	black	Track N inv. (zero pulse inv.)
Pin 5	brown	Track A
Pin 6	green	Track A inv.
Pin 7	–	–
Pin 8	grey	Track B
Pin 9	–	–
Pin 10	white/green	GND
Pin 11	white	GND-Sense
Pin 12	brown/green	UB

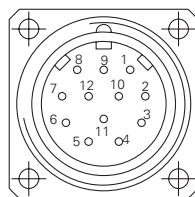

UB-Sense and GND-Sense are directly connected to UB resp. GND. Please use cores twisted in pairs (for example track A / track A inv.) for extension cables of more than 10 m length.

Trigger level

Outputs	Linedriver RS422
Output level High	>2.5 V (I = -20 mA)
Output level Low	<0.5 V (I = 20 mA)
Load High	<20 mA
Load Low	<20 mA

Outputs	Push-pull short-circuit proof
Output level High	>UB -3 V (I = -20 mA)
Output level Low	<0.5 V (I = 20 mA)
Load High	<20 mA
Load Low	<20 mA

Incremental encoders

Hollow shaft max. $\varnothing 14$ mm

Resolution 5..6000 pulses

GI331, GI333

Dimensions

GI331 hollow shaft and pin

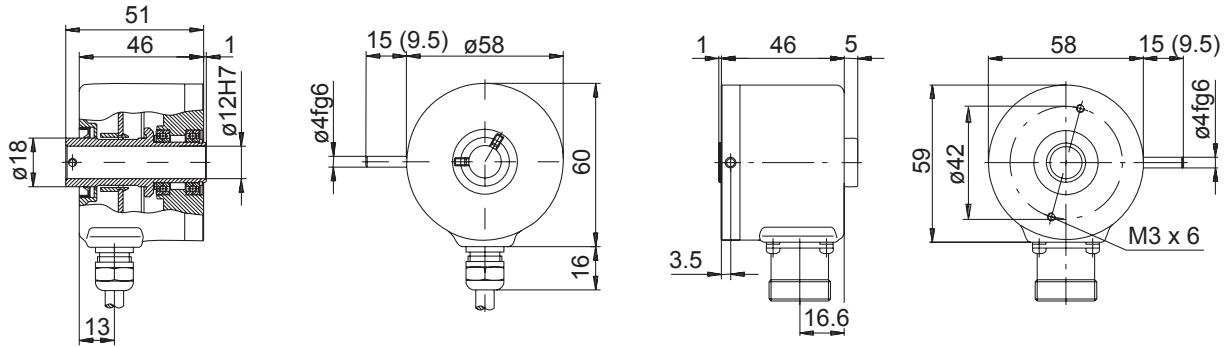

GI333 hollow shaft and clamping ring on housing

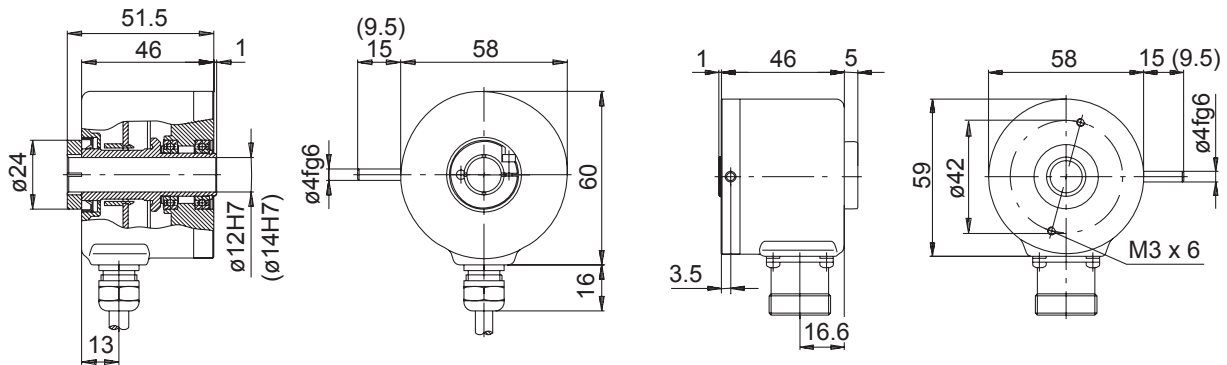

GI331, GI333 connector dimensions

