

Incremental encoders

Mini series, with hollow shaft

Resolution 5...2048 pulses

GI338



GI338 with hollow shaft

Features

- Mini encoder with end or hollow shaft
- Resolution max. 2048 ppr
- Housing $\varnothing 40$ mm
- High rotation speed max. 12000 rpm
- Operating temperature range -20...+85°C
- End shaft max. $\varnothing 12$ mm, hollow shaft max. $\varnothing 6$ mm
- Cost-efficient mounting

Technical data - electrical ratings

Voltage supply	5 VDC ± 10 % 10...30 VDC
Reverse polarity protection	Yes (10...30 VDC)
Consumption w/o load	≤ 60 mA
Resolution (steps/turn)	5...2048
Reference signal	Zero pulse, width 90°
Sensing method	Optical
Output frequency	≤ 100 kHz
Output signals	A 90° B, N + inverted
Output circuit	Linedriver RS422 Push-pull short-circuit proof
Interference immunity	DIN EN 61000-6-2
Emitted interference	DIN EN 61000-6-4

Technical data - mechanical design

Housing	$\varnothing 40$ mm
Shaft	$\varnothing 6$ mm hollow shaft $\varnothing 8$ mm end shaft $\varnothing 12$ mm end shaft
Protection DIN EN 60529	IP 42 IP 64
Operating speed	≤ 6000 rpm IP 65 ≤ 12000 rpm IP 42
Materials	Housing: polyamide black Flange: aluminium Shaft: stainless
Operating temperature	-20...+85 °C
Relative humidity	95 % non-condensing
Resistance	DIN EN 60068-2-6 Vibration 10 g, 16-200 Hz DIN EN 60068-2-27 Shock 50 g, 11 ms
Weight approx.	85 g
Connection	Cable 1 m

Output signals

Clockwise rotating direction when looking at flange.

Output signals 5 VDC, linedriver

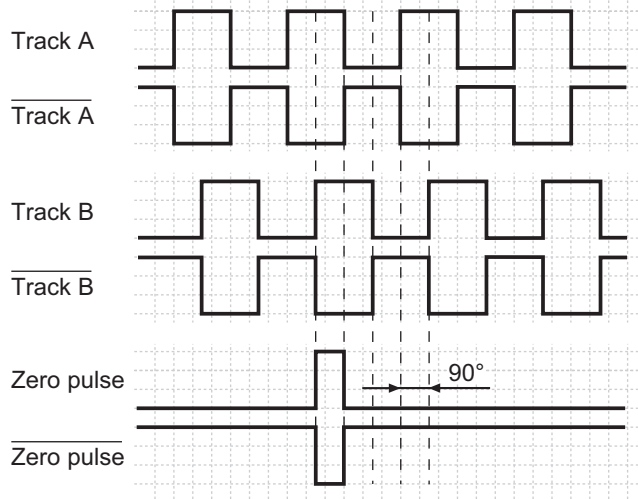

Clockwise rotating direction when looking at flange.

Output signals 10...30 VDC, push-pull

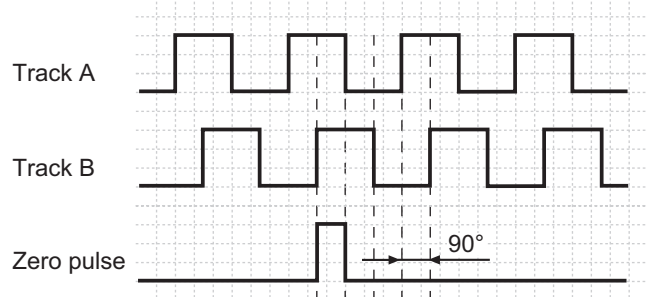

Incremental encoders

Mini series, with hollow shaft

Resolution 5...2048 pulses

GI338

Part number

GI338.

		41	
--	--	----	--

See part number (pulses)

Connection

41 Cable 1 m, radial

Voltage supply / signals

22 5 VDC / linedriver RS422

60 10...30 VDC / push-pull

Hollow shaft

- 0 Hollow shaft $\varnothing 6$ mm torque support / IP 64
- 1 Hollow shaft $\varnothing 6$ mm spring washer / IP 64
- 3 End shaft $\varnothing 8$ mm spring coupling / IP 64
- 4 Hollow shaft $\varnothing 6$ mm torque support / IP 42
- 7 End shaft $\varnothing 12$ mm spring coupling / IP 64

Part number (pulses)

49 (5)	06 (200)	15 (500)	29 (2048)
39 (50)	09 (250)	22 (1000)	
40 (60)	13 (360)	23 (1024)	
41 (100)	14 (400)	28 (2000)	

Other pulse numbers upon request.
Example: order key 23 = 1024 pulses.

Terminal assignment

Linedriver

Core colour Assignment

brown UB

green Track A

red Track A inv.

yellow Track B

blue Track B inv.

pink Track N (zero pulse)

grey Track N inv. (zero pulse inv.)

white GND

Push-pull

Core colour Assignment

brown UB

green Track A

yellow Track B

pink Track N (zero pulse)

white GND

Please use cores twisted in pairs (for example track A / track A inv.) for extension cables of more than 10 m length.

Dimensions

GI338 hollow shaft $\varnothing 6$ mm / torque support

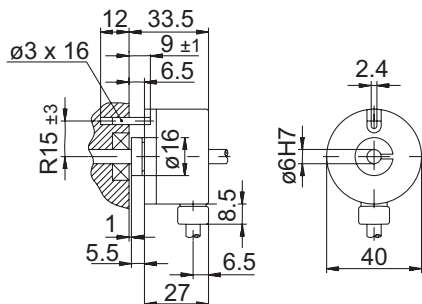

GI338 hollow shaft $\varnothing 6$ mm / spring washer

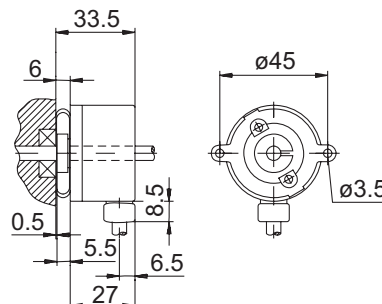

GI338 end shaft $\varnothing 8$ mm

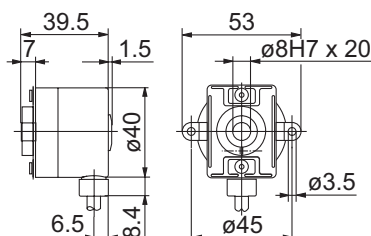

GI338 end shaft $\varnothing 12$ mm

