

Absolute encoders - bus interfaces

Shaft with clamping or synchro flange

Optical multiturn encoders 13 bit ST / 12 bit MT, RS485

GXM7W - RS485



GXM7W with clamping flange

Technical data - electrical ratings

Voltage supply	10...30 VDC
Reverse polarity protection	Yes
Consumption w/o load	≤50 mA (24 VDC)
Initializing time (typ.)	250 ms after power on
Interface	RS485
Function	Multiturn
Transmission rate	38.4 kBaud
User address	Coded by connection
Steps per turn	8192 / 13 bit
Number of turns	4096 / 12 bit
Absolute accuracy	±0.025 °
Sensing method	Optical
Code	Binary
Code sequence	CW/CCW coded by connection
Output circuit	RS485
Interference immunity	DIN EN 61000-6-2
Emitted interference	DIN EN 61000-6-4
Approval	UL approval / E63076

Features

- Encoder multiturn / RS485
- Optical sensing
- Resolution: singleturn 13 bit, multiturn 12 bit
- Clamping or synchro flange
- Fieldbus protocol
- Max. 4 bus users
- Bus access according to master/slave principle

Optional

- Integration of customer-specific RS485 protocols

Technical data - mechanical design

Housing	ø58 mm
Shaft	ø10 mm (clamping flange) ø6 mm (synchro flange)
Flange	Clamping or synchro flange
Protection DIN EN 60529	IP 54 without shaft seal IP 65 with shaft seal
Operating speed	≤10000 rpm (mechanical) ≤6000 rpm (electric)
Starting torque	≤0.015 Nm IP 54 ≤0.03 Nm IP 65
Rotor moment of inertia	20 gcm ²
Admitted shaft load	≤20 N axial ≤40 N radial
Materials	Housing: steel Flange: aluminium
Operating temperature	-25...+85 °C -40...+85 °C (optional)
Relative humidity	95 % non-condensing
Resistance	DIN EN 60068-2-6 Vibration 10 g, 16-2000 Hz DIN EN 60068-2-27 Shock 200 g, 6 ms
Weight approx.	400 g
Connection	Connector M23, 12-pin Cable 1 m

Absolute encoders - bus interfaces

Shaft with clamping or synchro flange

Optical multiturn encoders 13 bit ST / 12 bit MT, RS485

GXM7W - RS485

Terminal significance	
UB	Encoder voltage supply.
GND	Encoder ground connection relating to UB.
T,R IN T,R OUT	Serial data lines. To avoid stub lines the data lines are guided outside on a pair of 2 wires. The arriving bus is on T,R+ IN and T,R- IN, the departing bus on T,R+ OUT und T,R-. If the encoder serves as bus termination or is the only user, only the pair of wires T,R+ IN and T,R- IN is utilized. Note: External connection of terminating resistor 150 Ω to final user.
Zero setting	Input for setting a zero point anywhere within the programmed encoder resolution. The zero setting operation is triggered by a High impulse and has to be in line with the selected direction of rotation (UP/DOWN). Connect to GND after setting operation for maximum interference immunity. Impulse duration ≥ 100 ms.
UP/DOWN	UP/DOWN counting direction input. This input is standard on High. UP/DOWN means ascending output data with clockwise shaft rotation when looking at flange. UP/DOWN-Low means ascending values with counterclockwise shaft rotation.
Ident 1...2	Ident 1...2 are utilized for setting the encoder addresses (identifiers). Less potential the inputs are internally against UB (=“1”) by pull-up resistors what equals address 2.

Address	2	3	4	5
Ident 1	1	0	1	0
Ident 2	1	1	0	0

Terminal assignment		
Connector	Core colour	Assignment
Pin 1	brown	UB
Pin 2	black	GND
Pin 3	blue	T,R+ IN
Pin 4	beige	Ident 1
Pin 5	green	T,R- OUT
Pin 6	yellow	Ident 2
Pin 7	violet	T,R- IN
Pin 8	brown/yellow	UP/DOWN
Pin 9	pink	T,R+ OUT
Pin 10	black/yellow	Zero setting
Pin 11	–	–
Pin 12	–	–

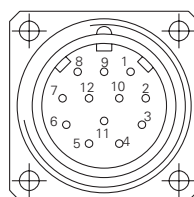

Please use cores twisted in pairs (for example T,R+ / T,R-) for extension cables of more than 10 m length.

Trigger level	
Interface	Circuit
Data	Linedriver RS485

Control inputs	Input circuit
Input level High	>0.7 UB
Input level Low	<0.3 UB
Input resistance	10 kΩ

Absolute encoders - bus interfaces

Shaft with clamping or synchro flange

Optical multiturn encoders 13 bit ST / 12 bit MT, RS485

GXM7W - RS485

Dimensions

GXM7W clamping flange

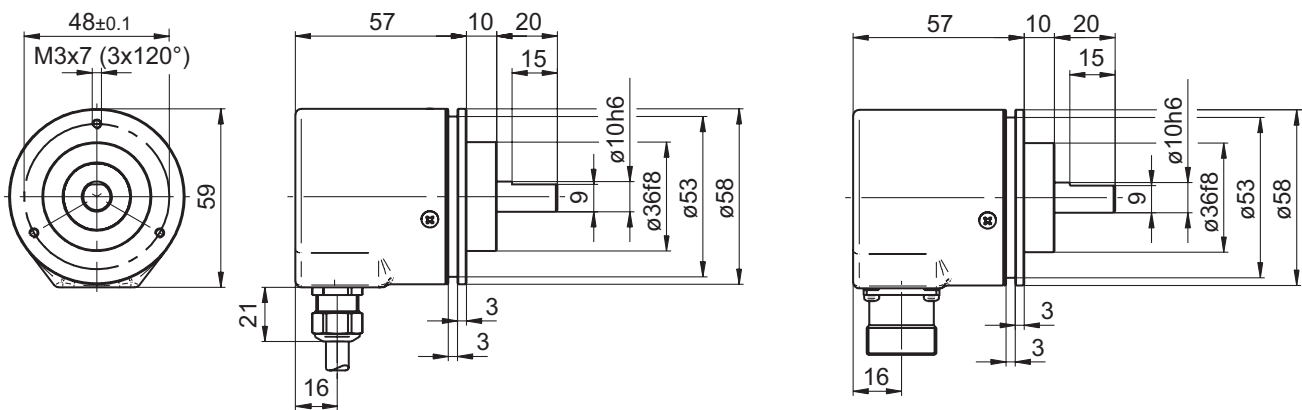
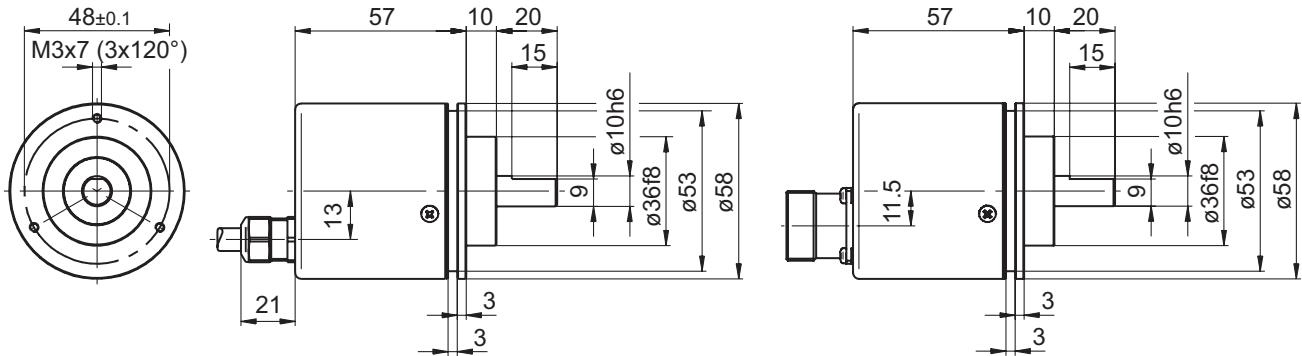

GXM7W synchro flange

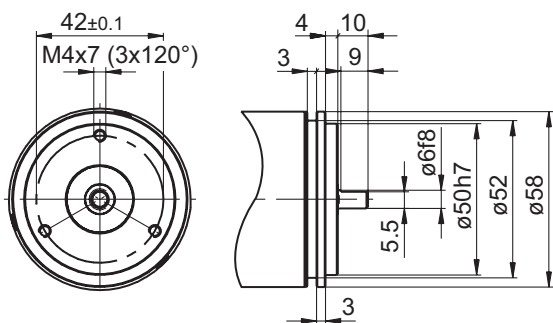

GXM7W connector dimensions

