

# SI 251

## Sine/Cosine Interpolator with Adjustable Multiplication Rate, for Use with Sine/Cosine Encoder Systems



- Converts sinus wave inputs with 1 V<sub>ss</sub> standard level into incremental quadrature output signals
- Outputs A, /A, B, /B, Z, /Z (RS422 / TTL) and A, B, Z (80 – 30 V HTL)
- Adjustable multiplier for interpolation rates from 1:5 to 1:50
- Adjustable divider 1:1 – 1:128 to reduce the output frequency
- Sinus-input frequency 0 - 400 kHz
- Quadrature output frequency up to 4 MHz
- Adjustable glitch filter
- Power supply 18 – 30 VDC

## Operating Instructions



## Safety Instructions

- This manual is an essential part of the unit and contains important hints about function, correct handling and commissioning. Non-observance can result in damage to the unit or the machine or even in injury to persons using the equipment!
- The unit must only be installed, connected and activated by a qualified electrician
- It is a must to observe all general and also all country-specific and application-specific safety standards
- When this unit is used with applications where failure or maloperation could cause damage to a machine or hazard to the operating staff, it is indispensable to meet effective precautions in order to avoid such consequences
- Regarding installation, wiring, environmental conditions, screening of cables and earthing, you must follow the general standards of industrial automation industry
- - Errors and omissions excepted –

Version:	Description:
SI25101a/ AF/ Nov. 04	Original
SI25101b/ AF/HK/ Feb.05	Corrections with connectors male/female, DIL2 settings and miscellaneous small bugs

# Table of Contents

1. Introduction .....	4
2. Block Diagram .....	5
3. Connections .....	6
4. Pin assignment of SUB-D-connectors .....	8
4.1. Sine/Cosine inputs .....	8
4.2. RS 422 impulse output .....	9
5. Switch settings .....	10
6. Frequency Divider and Error Signals .....	13
7. Delays .....	14
8. Miscellaneous Hints .....	14
9. Dimensions .....	15
10. Technical Data .....	16

# 1. Introduction

SI251 represents an encoder interface unit, designed to convert output signals of so-called "sine-cosine-encoders" and similar measuring systems into incremental quadrature impulse signals.

Under consideration of an adjustable multiplier the unit interpolates a corresponding number of impulses from every sine wave. An additional programmable divider provides division of the impulses if applicable, before they appear at the output. Impulses are available with TTL/RS422 standard (A, /A, B, /B, Z, /Z) and with HTL standard (A, B, Z, 18-30V) at the same time.

SI251 also possesses a selectable glitch filter to minimize interferences on the signal lines. The maximum sine input frequency is 400 kHz. The interpolation rate can be set in a range from 5 to 50, i.e. the unit can generate up to 50 pulses from one sine period. The maximum output frequency is 4 MHz with use of the RS422 output, and approx. 100 kHz when the HTL output is used. Where applicable, the output frequency can be reduced by a selectable divider 1:1 – 1:128.

Independent of the selected interpolation rate, an interpolation time can be set in order to limit the output frequency to a desired maximum value.

The unit provides auxiliary output voltages of 5.2 volts and approx. 20 volts, all short-circuit-proofed, for power supply of the sine/cosine encoder.

Errors will be signaled by a LED and at the same time by a digital control output. Errors can be reset by means of a pushbutton on the unit, or by a remote reset signal.

All settings are done by means of two DIL switches which are accessible from the top site and the bottom site of the housing.

The mechanical construction provides a compact housing for rail mounting, with 12 screw terminals and two Sub-D-connectors

## 2. Block Diagram

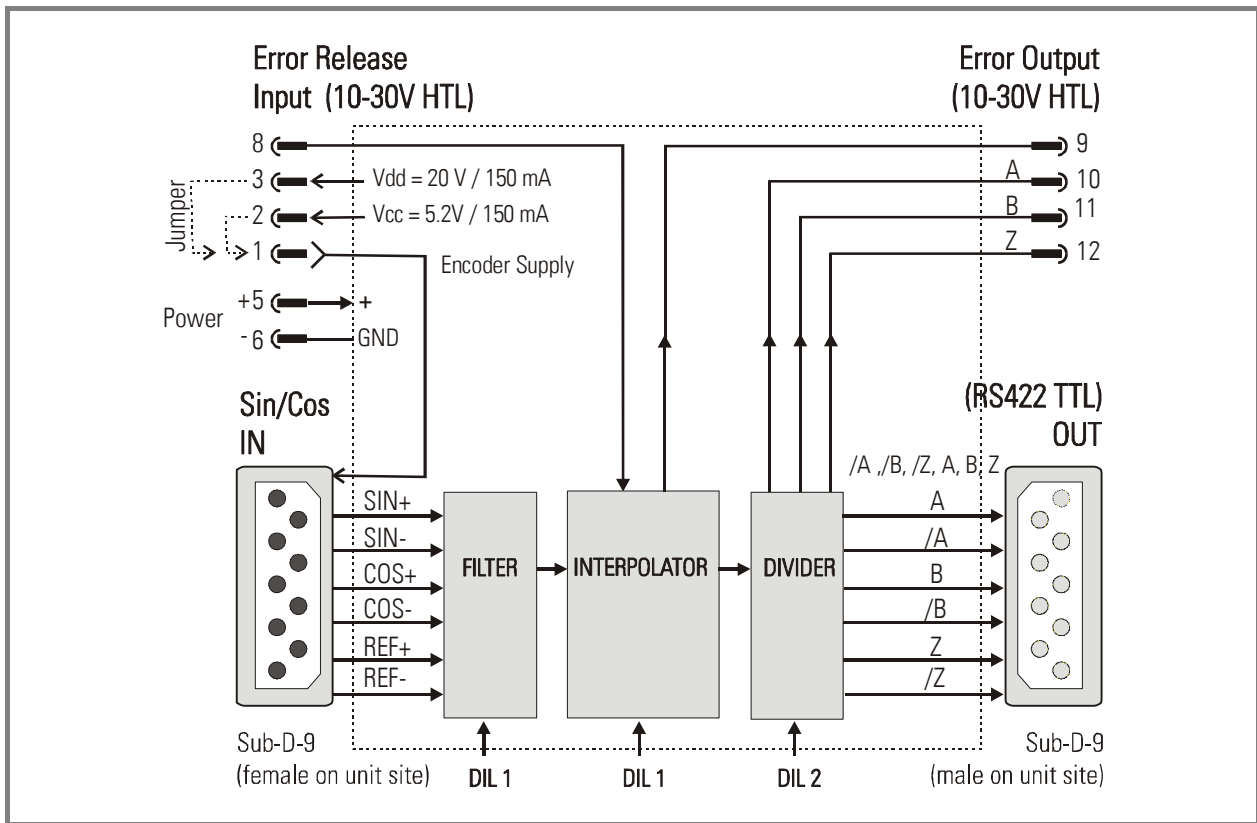

### 3. Connections

The unit provides a 9-pin Sub-D connector (female on the unit site) for connection of the sine/cosine sensor. For easy power supply of the encoder, an external jumper allows to switch an auxiliary voltage of either 5.2 volts or approx. 20 volts to the same connector. Also the mean voltage is available on the connector pins, allowing also the use of sensors with non-differential sinus output.

The incremental output impulses are available with RS422 standard and HTL standard (push-pull) at the same time, and one output of both or both outputs at a time may be used, quite according to the application.



**All inputs and outputs as well as the power supply refer to the same reference potential (GND)!**

In case of errors the Error Output switches to HIGH. At the same time the yellow front LED will be lit.

To release an Error state, a HIGH signal must be applied to the "Error Release" input (PNP, HTL, a positive signal of 10-30 volts will release the error). Errors may be cleared also by pushing the small button on the top site of the unit.

The unit operates with a 18 – 30 volts DC power applied to terminals 5 (+) and 6 (-)

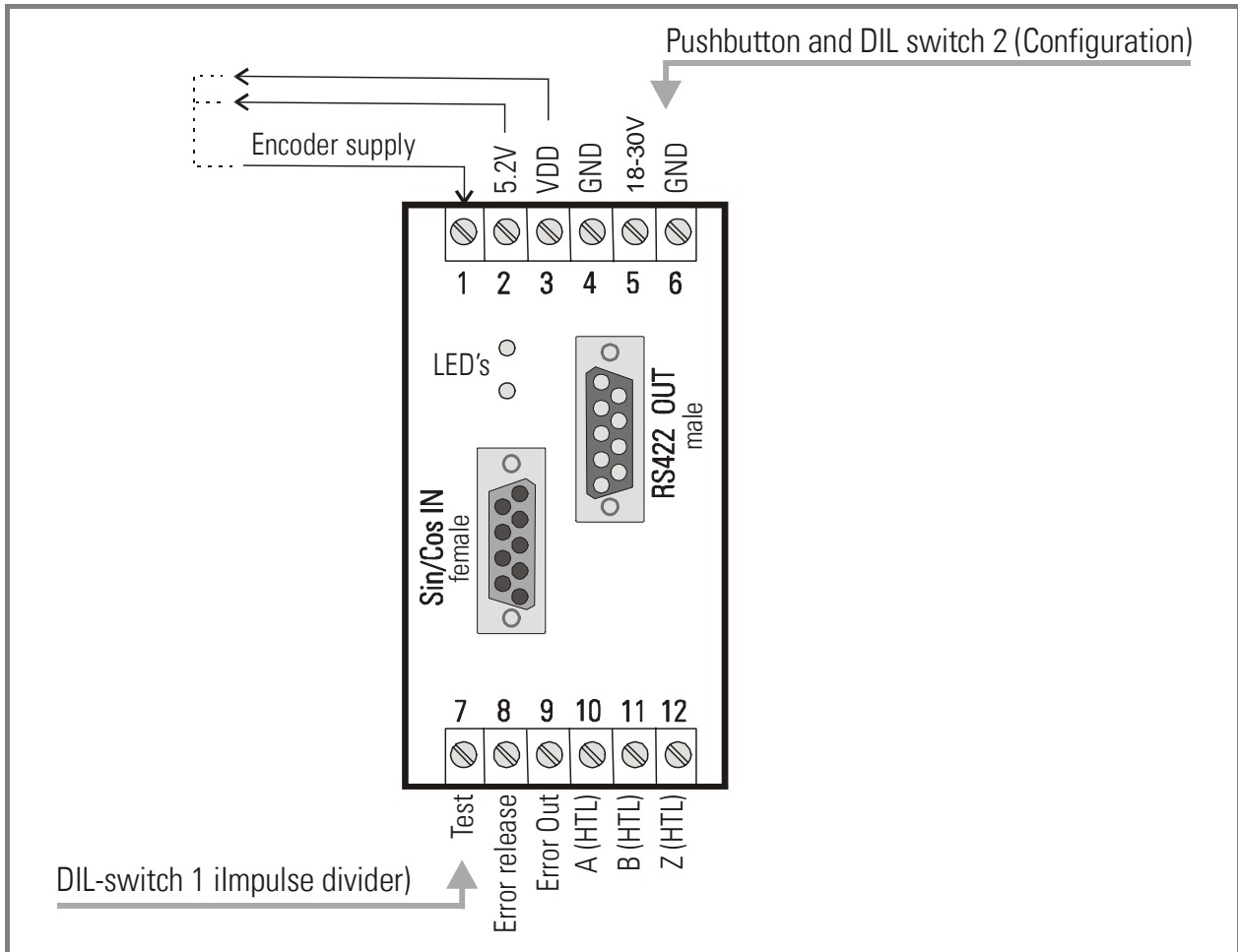

At any time, the over-all transmission characteristics of encoder, external components and capacity of cable must ensure proper signals at the input of the unit, with respect to levels, shape and phase displacement A/B.

The output swing of the HTL push- pull outputs corresponds to the input supply voltage on terminals 5 and 6.

## 4. Pin assignment of SUB-D-connectors

### 4.1. Sine/Cosine inputs

Standard encoders with differential outputs can be connected directly to the corresponding pins **SIN+**, **SIN-**, **COS+**, **COS-**, **REF+**, **REF-**.

Where longer cables must be used, terminating resistors between the non-inverted and the inverted signal of each channel may be of advantage.

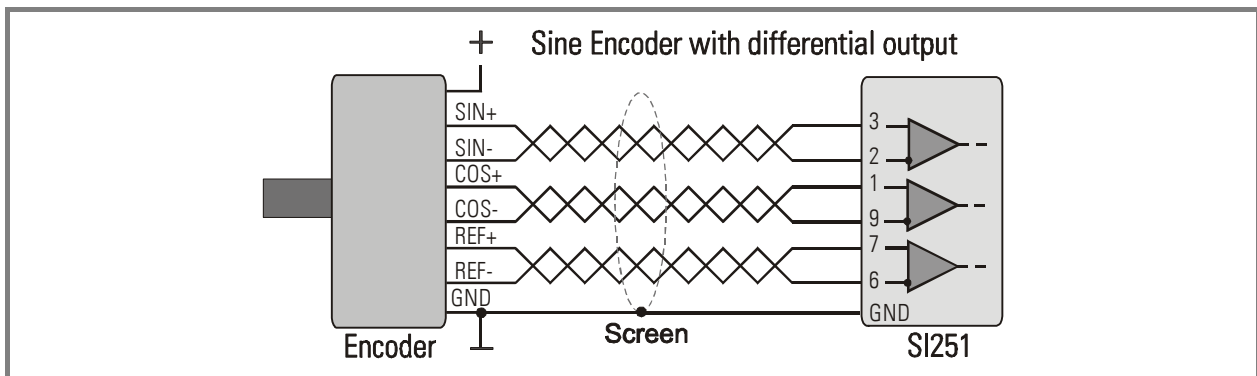
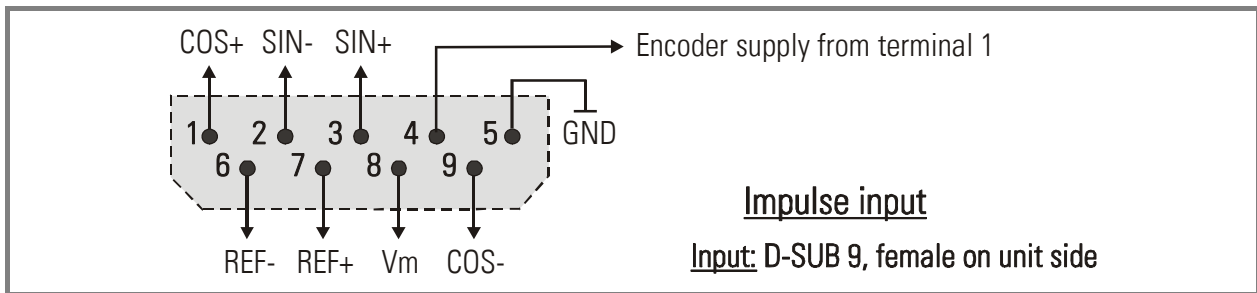

With sensors using single-ended outputs, the sensor signals **SIN**, **COS** and **REF** are connected to the corresponding input pins. The inverted inputs of the unit are tied to either the mean voltage output **V<sub>m</sub>** (pin 8) of the unit, or to a corresponding voltage reference of the sensor itself

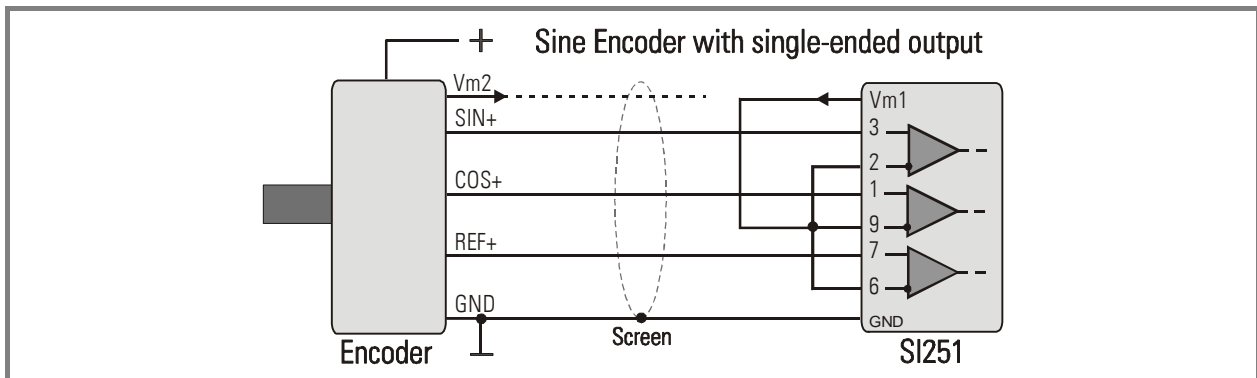

When the reference signals REF+ and REF- are not used or not available, the related inputs of the converter must be tied to a defined potential.

When you connect the REF- pin to Vm with the REF+ pin open, the unit will generate a Z impulse with every sine period.

When you connect the REF+ pin to Vm with the REF- pin open, the unit will not generate a Z impulse.



The sine-cosine signals on the input site are highly sensitive analogue signals! Therefore it is mandatory to use proper screening. Use of cables with pair wise twisted leads is highly recommended. The cable length should not exceed 5 meters if possible.

With critical applications, a terminating impedance (approx. 470 ohms, and where required a capacitor of 680 pF to 4.7 nF) connected between the differential inputs may be helpful.

## 4.2. RS 422 impulse output

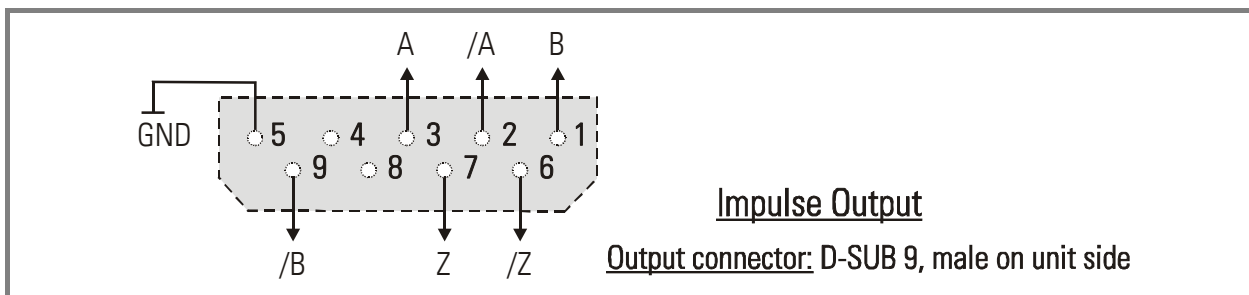

## 5. Switch settings

Switch DIL1 allows to set the filter and to choose the interpolation rate and interpolation time. Switch DIL2 selects a programmable divider and allows to set the unit to test mode



Changes of the DIL switch positions will become active only after the next power-up of the unit!

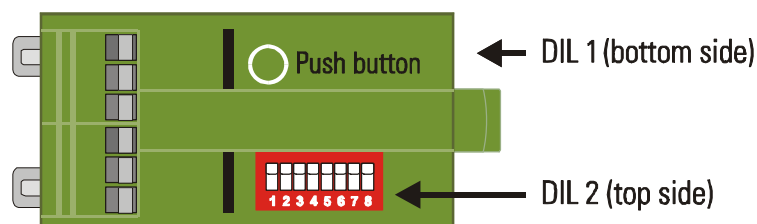

DIL1: ( 0 = OFF, 1 = ON )								Interpolation and Filtering	
8	7	6	5	4	3	2	1		
						1	1	Minimum Filter	Filtering
						1	0	Filter 10kHz	
						0	1	Filter 100 kHz	
					1			Glitch-Filter OFF	
					0			Glitch-Filter ON	
		1	1	1				40	Interpolation rate
		1	1	0				20	
		1	0	1				10	
		1	0	0				5	
		0	1	1				50	
		0	1	0				25	
		0	0	1				12,5	
		0	0	0				6,25	
1	1							25ns	Interpolation time
1	0							100ns	
0	1							400ns	
0	0							1600ns	



### Hints for settings of DIL switch 1:

- Under proper electrical conditions there is no imperative need to use the filtering functions offered in the table above. When you set your interpolation factor with use of the filter settings highlighted in the table, there will be no further restrictions with the operating range of the unit.
- Use of the filtering functions will eliminate noise on the signal lines, but at the same time result in some limitations and restrictions of the operating range. The sine input frequency must not exceed the selected filter frequency. Where you decide to use the 100 kHz filter, the unit will not respond to frequencies higher than 100 kHz.
- Distortions of the input signal result in fluctuation of the output frequency.
- Use of the glitch filter results in increased interpolation times at standstill or with low input frequencies, therefore reduces noise and jitter of the output signal by a few increments up and down in standstill. However, when the glitch filter is switched on, fast changes of the speed can result in temporary proportional errors between input frequency and output frequency during acceleration

The subsequent table shows the limits of input and output frequencies with respect to the DIL switch settings:

Interpolation rate	Interpolation time	Maximum output frequency	Maximum input frequency
x5	25 ns	2 MHz	400 kHz
	100 ns	2 MHz	400 kHz
	400 ns	625 kHz	125 kHz
	1600 ns	156.25 kHz	31.25 kHz
x6,25	25 ns	2,5 MHz	400 kHz
	100 ns	2,5 MHz	400 kHz
	400 ns	625 kHz	100 kHz
	1600 ns	156.25 kHz	25 kHz
x10	25 ns	4 MHz	400 kHz
	100 ns	2,5 MHz	250 kHz
	400 ns	625 kHz	62.5 kHz
	1600 ns	156.25 kHz	15.625 kHz

Interpolation rate	Interpolation time	Maximum output frequency	Maximum input frequency
x12,5	25 ns	4 MHz	320 kHz
	100 ns	2.5 MHz	200 kHz
	400 ns	625 kHz	50 kHz
	1600 ns	156.25 kHz	12.5 kHz
x20	25 ns	4 MHz	200 kHz
	100 ns	2.5 MHz	125 kHz
	400 ns	625 kHz	31.25 kHz
	1600 ns	156.25 kHz	7.8125 kHz
x25	25 ns	4 MHz	160 kHz
	100 ns	2.5 MHz	100 kHz
	400 ns	625 kHz	25 kHz
	1600 ns	156.25 kHz	6.25 kHz
x40	25 ns	4 MHz	100 kHz
	100 ns	2.5 MHz	62.5 kHz
	400 ns	625 kHz	15.625 kHz
	1600 ns	156.25 kHz	3.90625 kHz
x50	25 ns	4 MHz	80 kHz
	100 ns	2.5 MHz	50 kHz
	400 ns	625 kHz	12.5 kHz
	1600 ns	156.25 kHz	3.125 kHz

## 6. Frequency Divider and Error Signals

The programmable frequency divider provides decrease of the output frequency by an adjustable division rate between 1:1 and 1: 128.

The following errors are detected and indicated by the yellow LED and the Error output:

- Wire break with one of the signals SIN+, SIN-, COS+ or COS-
- Too low amplitude on one of above signal lines
- The input frequency exceeds it's maximum level, the output frequency is unable to follow
- The signals REF+ and REF- are not subject of the error check procedure. Depending on the settings on the DIL2 switch, error signals remain active until remote acknowledgement, or reset automatically upon elimination of the error.
- In case of an error the proper function of the unit is not ensured and a loss of encoder pulses can occur.

DIL2: ( 0 = OFF, 1 = ON )								Divider and testing functions	
8	7	6	5	4	3	2	1		
		1	1	1	1	1	1	1 : 2	Division rate
		1	1	1	1	1	0	1 : 4	
		1	1	1	1	0	1	1 : 6	
		1	1	1	1	0	0	1 : 8	
		1	1	1	0	1	1	1 : 10	
		1	1	1	0	1	0	1 : 12	
		1	1	1	0	0	1	1 : 14	
		1	1	1	0	0	0	1 : 16	
		1	1	0	1	1	1	1 : 18	
-----								-----	
		0	0	0	0	0	0	1 : 128	
	1							Automatic error reset	Error LED and output
	0							Static error message	
0								Divider switched on	Divider
1								Divider switched off	

## 7. Delays

There is a delay time between the analogue input signals and the incremental output signals, which is typically 3  $\mu\text{sec}$ . when the divider is switched off.

Use of the divider function will extend the delay time correspondingly.

Since the delay time is constant, there will be a phase displacement between input and output, depending on the actual frequency.

## 8. Miscellaneous Hints

- The unit will reach full accuracy only after a transient period of approximately 20 full sine cycles at the input. Before that, the input frequency should not exceed about 50 % of the normal maximum frequency
- The application of digital interpolation procedures requires use of quantization steps, which can cause a certain dither of the output signal.
- The quality of the output signal depends essentially on the input signals. Therefore maximum elaborateness is recommended with screening, running of cables and cable length.
- SI251 does not possess a potential separation, i.e. the unit GND is at the same time also GND of the sensor. Therefore it is important to ensure clear conditions with earthing and to prevent earth loops and balance currents flowing through the unit. Where unrulable potential situations should come up, it is recommended to use a fully separate power supply for the SI 251 unit

# 9. Dimensions

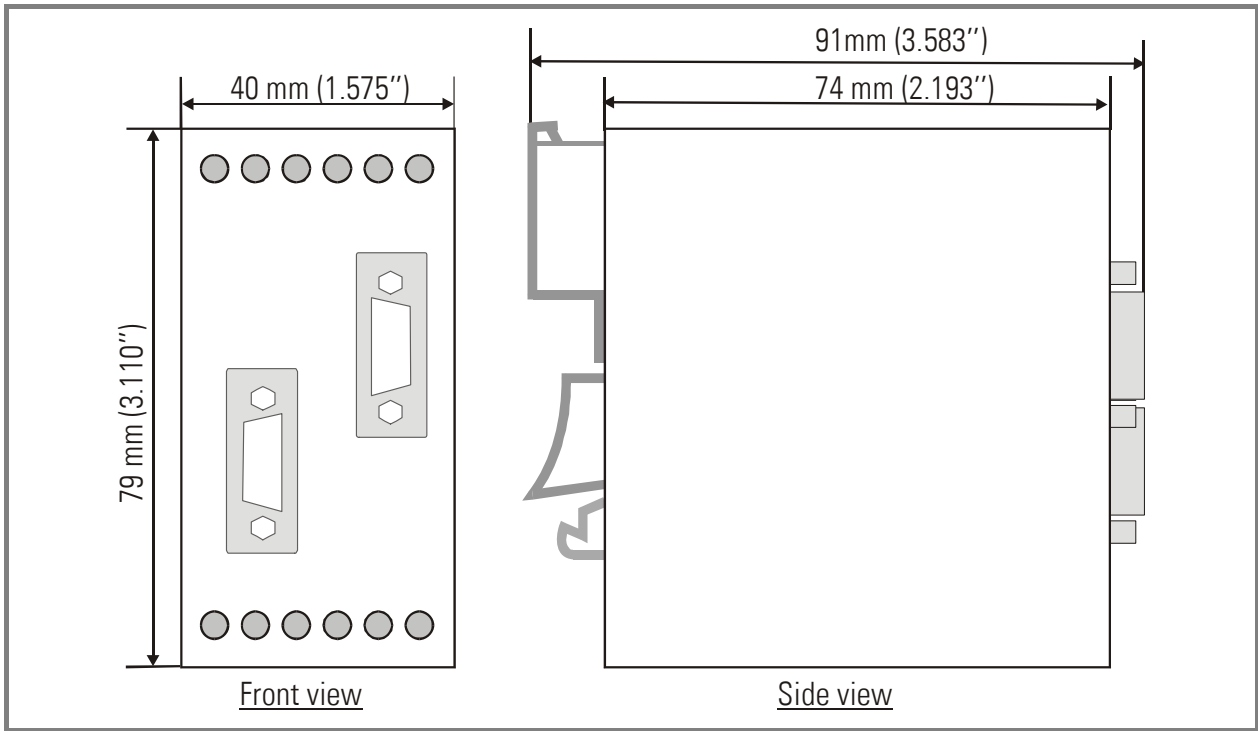

## 10. Technical Data

Power Supply (with no external load)	:	Vdd = 18 V DC (0.15 A) – 30 V DC (0.09 A)
Aux. Voltage Output 1	:	5.2 V / max. 150 mA
Aux. Voltage Output 2	:	Vdd – 4V / max. 150 mA
Input frequency	:	max. 400 kHz
Amplitude Sine/Cosine Inputs	:	min. 0.8 Vpp – max. 1.2 Vpp
DC Offset Sin/Cos Inputs	:	min. 1.8V – max. 3.1V
Differential Ref Input: High	:	130mV ; Low : 40mV
Output voltage HTL	:	Vdd – 4V
Output voltage HTL Error	:	Vdd – 4V
Output current HTL	:	max. 40 mA (push-pull)
Input level HTL	:	LOW < 4 V, HIGH > 10 V
Input resistance HTL	:	approx. 10 k $\Omega$
Operating temperature range	:	0...+45 °C / 32...110 °F
Weight	:	approx. 200 g
Conformity and Standards	:	EMC 89/336/EEC : EN 61000-6-2 EN 61000-6-3 LV73/23/EEC : EN 61010-1