

## Instruction Manual

for



# PS 125

## Low Cost Positioning Module

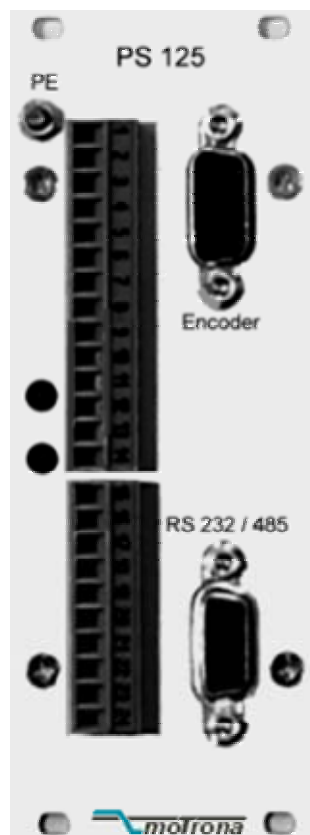

- Provides full set of functions for any kind of closed-loop position control
- Includes Index and Print Mark Control
- 100kHz of feedback frequency
- Highly dynamic, only 500 µsec of response time
- Easy PC-setting by PC operator software

<b><u>Table of Contents:</u></b>		<b>Page</b>
<b>1.</b>	<b>Principle of Register Settings and Changes</b>	<b>3</b>
<b>2.</b>	<b>Connection and Hardware Settings</b>	<b>4</b>
<b>3.</b>	<b>Setting of Register</b>	<b>8</b>
<b>4.</b>	<b>Serial Interface</b>	<b>12</b>
<b>5.</b>	<b>Overview Parameter Setting</b>	<b>14</b>
<b>6.</b>	<b>Overview Commands</b>	<b>15</b>
<b>7.</b>	<b>Overview Variables</b>	<b>16</b>
<b>8.</b>	<b>Operator Surface OS3.0</b>	<b>17</b>
<b>9.</b>	<b>Steps for Commissioning</b>	<b>19</b>
<b>10.</b>	<b>Specifications and Dimensions</b>	<b>19</b>

## 1. Principle of Register Settings and Changes

For general set-up, the operator software „OS30“ is included in delivery (supplied on disc). This software allows to set all parameters and registers upon commissioning, using a PC with Windows 3.x or Windows 95 operating systems. All settings, with a few exceptions, are based on serial communication.

Where we need to change position, speed ratio or other parameters ,due to different production conditions, there are three ways to do this:

- 1.1 By serial communication with a PC or a PLC.
- 1.2 By using the motrona mini operator terminal TX340. This unit is suitable to change a few parameters with one or two axis.
- 1.3 By using the motrona TX720 terminal which offers a wide range of serial communication and text/parameter editing for up to 32 drive axis. The subsequent pictures should provide you with a short impression of TX340 and TX720 and more information is available on request.



## 2. Connections and Hardware Settings

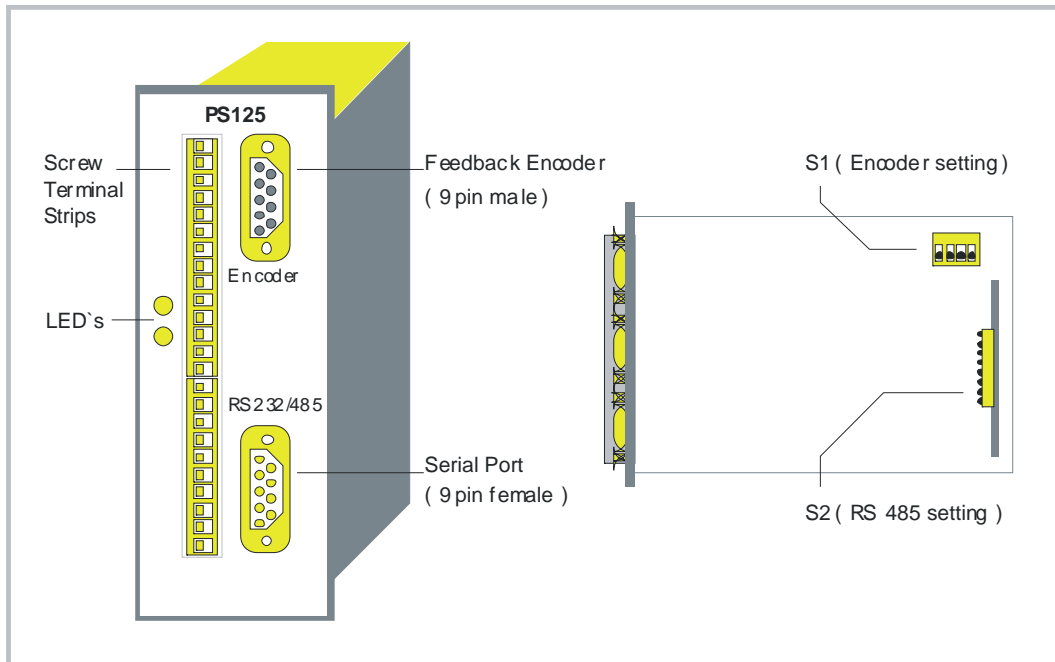

Fig.1

Fig. 1 shows the connectors available on the front plate, Fig. 2 shows the block diagram of the unit with its minimum peripheral configuration and Fig. 3 shows the screw terminal assignment.

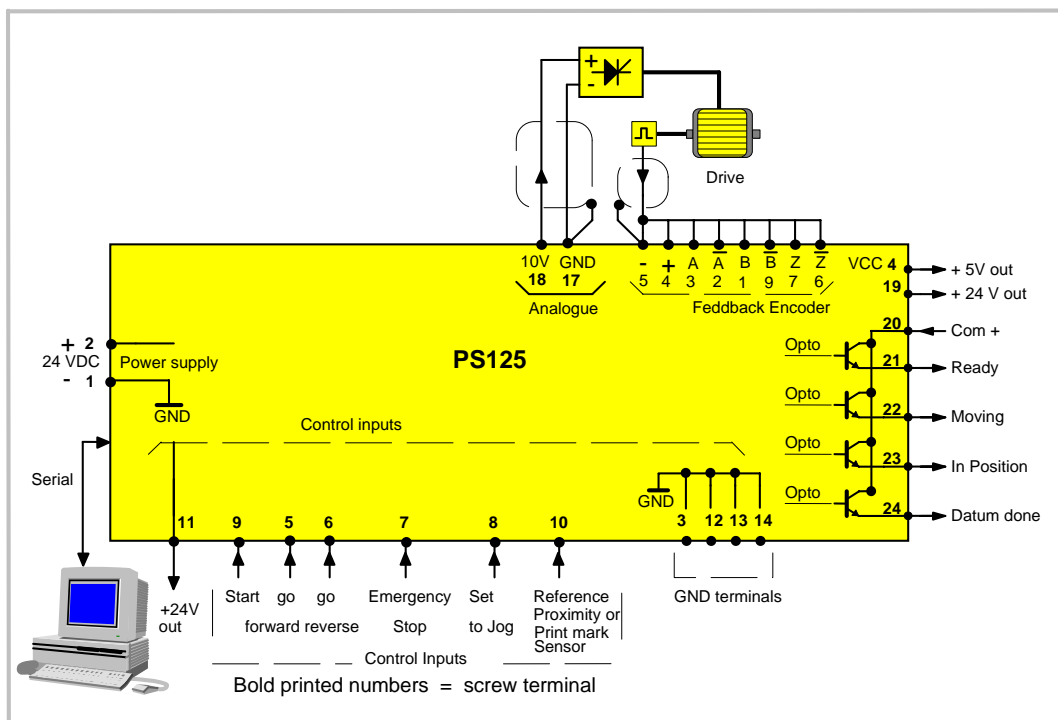

Fig 2

### 2.1 Power Supply

The PS125 operates from an un stabilised 24 VDC supply (+/- 25%), however, the voltage including ripple should not exceed the following limits (18 V...30 V). The supply of the PS125 is electrically protected against wrong polarity misconnection by protection diodes.

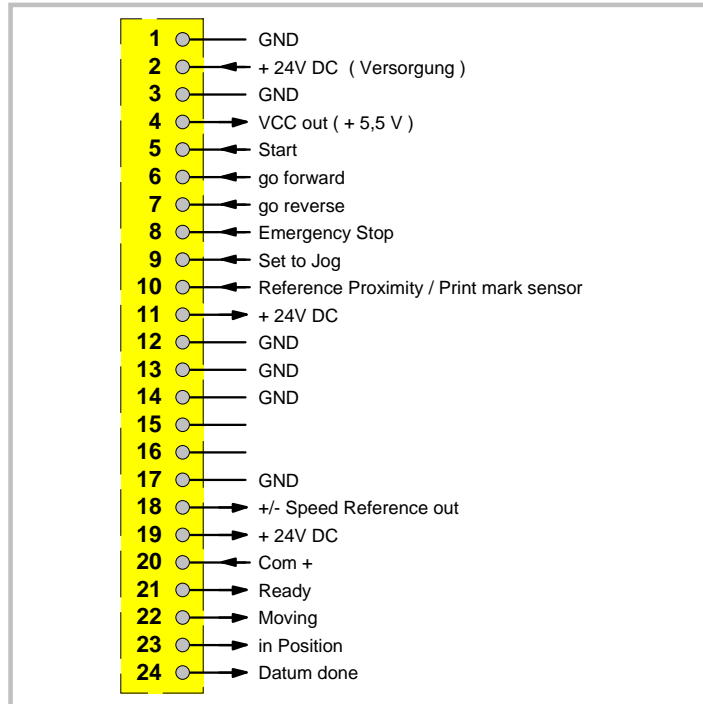

Fig 3

## 2.2. Encoders

The unit only accepts TTL impulse signals ( 5V, RS 422) or similar signals from an encoder simulation (resolver). It is essential to connect the channels A,  $\bar{A}$ , B,  $\bar{B}$  . The zero inputs Z and  $\bar{Z}$  can be omitted, if not needed.

Where you find you are working with existing 10-30 Volt encoder signals which feature only A/B/Z signals, the PU202 converter should be used to gain full complementary signals in line with RS-422 standards. Against special remark upon order, PS125 units can also be delivered with HTL encoder inputs ( A, B, 24V level).

An auxiliary voltage of **5,5 V (max. 500 mA total)** is available on encoder connector, for easy supply of the feedback encoder connector on the unit is Sub-D-9 pin, male.

Fig. 4 and Fig. 5 shows the encoder connection and the principle of the input circuit. When connecting the encoder it is not important to wire the A and B signals to produce the correct counting direction. The direction can be determined in the setup menu.

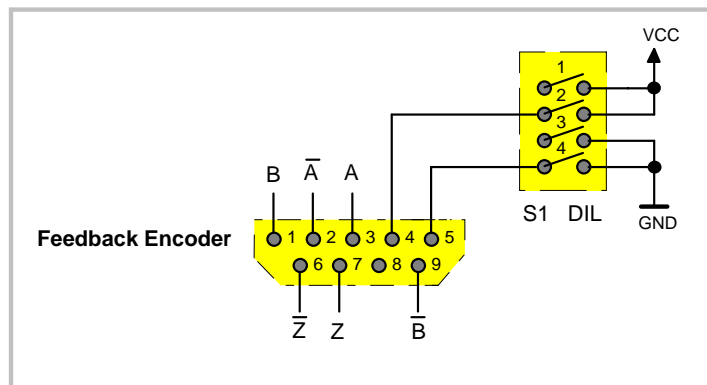

Fig 4

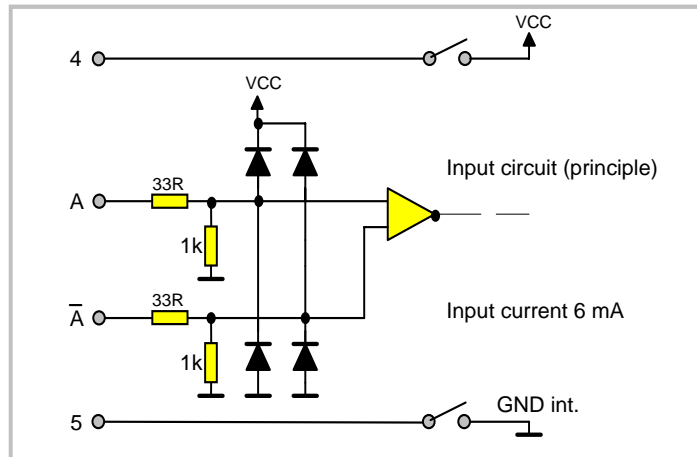

Fig 5

**Important**

The 4-position DIL switch S1 allows the desired encoder voltages to be set. See Fig. 1.

- **With encoder, supplied by the PS125:**  
Set positions 2 and 4 to "ON"  
Connector pins 4 and 5 provide the encoder supply.
- **With encoder, supplied by an external source, or when an encoder simulation from the drive is used:**  
Set position 2 to "OFF" and position 4 to "ON"  
Use connector pin 5 as common GND potential.
- For **fully differential** operation:  
Set positions 2 and 4 OFF

The inputs then operate in differential mode which is best in terms of noise immunity. However, the impulse source must be of line driver type with external supply, when this input mode is used.

**Warning:**

**When switch position 2 is "ON", you must ensure that no supply is applied to pins 4 and 5, as this will cause serious damage within the unit.**

**2.3 Control Inputs and Outputs**

There are 6 control input lines and 4 control output lines available on the screw terminals.

**All inputs are fully PLC compatible. All signals refer to GND and the minus potential of the supply.**

**All the outputs are opto-isolated transistor outputs which are also PLC compatible.**

<b>Logic 0 ( low ) = 0 .....5 Volts</b> <b>Logic 1 ( high ) = 18 .....30 Volts</b>
---

To avoid command latch errors, the command signal must stay in a stable state for at least 1 msec.

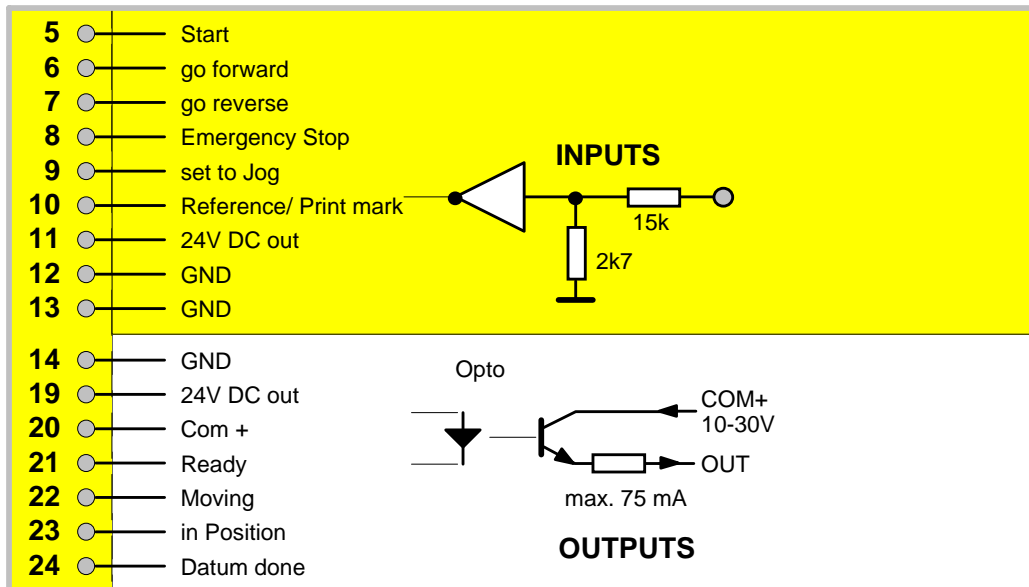

Fig. 6

## 2.4 Inputs

### Start (Pin 5):

A positive transition at this input will start next positioning cycle.

### go forward (Pin 6):

Depending on the setting of input **set\_to\_Jog** a positive transition or level at this input will cause the drive to move forward. If **Jog** is set the drive will move forward until the go forward command will be released. In reference mode the drive will move until it reaches it's reference position defined by register **Reference Mode**.

### go reverse (Pin 7):

As above, but in reverse direction.

### Emergency Stop (Pin 8):

This is an emergency stop input. When High, any positioning in progress will be aborted and the drive will go to standstill using the Emergency Ramp setting.

### Set to Jog (Pin 9):

When High the inputs **go forward** and **go reverse** will be set to jog mode. When Low, the inputs provide reference function.

### Reference Proximity / Print mark (Pin 10):

In modes 0 – 3, this input receives a signal from a limit switch or a proximity. Depending on the selected referencing mode, the drive will stop here, the **Datum done** output will switch on and the counter will be overwritten by the data of the register **Reference Position**.

In mode 4, this input receives a signal from a photocell or print mark sensor, and the rising edge will correct the next stop to match the print mark position

### Activate Data (serial only):

This command will load all buffer data to the operational RAM memory, i.e. new position and speed will now be active after the next start signal.

### Store EEPROM (serial only):

All buffer and RAM data will be lost upon power down and be replaced by the appropriate EEPROM data with next power up. This is valid for any serial modification of the registers. A Store EEPROM command however will save the complete operational data set to the EEPROM.

### Reset (serial only):

A reset command puts the position controller into open loop mode.

## 2.5 Outputs

### **COM + (Pin 20):**

Outputs are opto-isolated PNP type and an external voltage 5.....30 Volts must be applied to the „COM+“ terminal which then will appear at the outputs when High. Maximum output current is 75mA.

### **Ready (Pin 21):**

This announces that the unit is ready to run. On power up, this output is "Low" for about three seconds to allow the power supply to settle, and then switches to "High".

Warning:

When "High", the unit could not detect a system fault itself, but this is not a guarantee for fault-free operation!

### **Moving (Pin 22):**

This output is high whenever the speed is not zero and the drive is moving.

### **In Position (Pin 23):**

This output continuously compares the actual position to the actually required target position +/- a programmable position window. It goes high upon coincidence. It goes low again on next start command.

### **Datum done (Pin 24):**

Upon power up, this output remains low until a referencing cycle has been executed and the system has been calibrated by reading its reference position. It stays high all the time, unless a new reference cycle is started.

## 3. Setting of Registers

### 3.1 Data Settings

#### **Incremental Length (C00):**

This is a default setting for incremental operation, i.e. the position advances always the same distance upon each start. The unit will take this distance, unless otherwise specified remotely.

#### **Position Number (C01):**

This is a pointer to a position value stored in registers C20 to C39. In mode 2 the position number can be changed to select a new target position. In mode 3 the value represents the start position for the loop program.

**Attention:** In mode 3, this register is automatically incremented with each start and follows the branch instructions within a program loop. After an interruption of a loop cycle, be aware where the pointer is or set it to start position again.

#### **Mode (C02):**

This setting selects one of the five general modes of operation ( 0 - 4 ).

Mode	Operation	Description
<b>0</b>	Incremental Operation	C00 (Incremental Length) defines the next position. Target position = actual position + C00 Position direction is always forward.
<b>1</b>	Absolute Incremental Operation	C00 (Incremental Length) defines the next position with respect to the actual position error Target position = actual position + C00 - position error Position direction is always forward.
<b>2</b>	Absolute Operation	Target position is selected by C01 (Position Number) and the corresponding position value (C20 - C39) <b>Mode 2.1</b> A fixed set of positions stored in C20 - C39 can be selected by changing C01 (Position Number) <b>Mode 2.2</b> A new absolute position can be entered by changing the position value (C20 -C39) where C01 (Position Number) is pointing to.
<b>3</b>	Loop Operation	C01 (Position Number) will define the start position stored in C20 - C39 for a numerical sequence with consideration of branch instructions. C01 (Position Number) will be incremented with next start command.
<b>4</b>	Incremental Operation with print mark control	C00 defines the next position. A rising edge on printmark input 10 will not affect the position cycle which is actually in progress, but the subsequent target position will be overwritten by the print mark position, with respect of the Offset set to register "Ref. Position/ Photo Offset"

Fig. 7

**Accel Ramp to 100% (C03):**

Acceleration time from standstill to full speed..

**Decel Ramp from 100% (C04):**

Deceleration time from full speed to standstill.

**Emergency Ramp (C05):**

Deceleration time from full of speed to standstill. A setting of 0.000 sec. will result in a jump to zero.

**Pulses per 1000 (C06):**

This is a scaling factor permitting to set the positions in any kind of engineering units, independent of the feedback resolution. Set the number of encoder pulses generated by the encoder for a distance of 1000 engineering units here.

Example:

You desire to have a position preset with a 0.1 mm resolution. Consequently, your engineering units are 0,1 mm and 1000 engineering units will be 100 mm. If, i.e., the encoder would generate 1380 impulses to go 100 mm forward, set the register to "1380".

**Position Window (C07):**

This is a tolerance window around the target position. The controller will accept any position inside this window as a proper target position and keep it until to next start. Setting in engineering units.

**Frequency at 100% (C08):**

Maximum encoder feedback frequency at maximum speed. With this setting, the processor will calculate the optimal S-shape speed profile to go to the next target position.

**Speed Adjust (C09):**

This register is used to set the desired positioning speed from 0 to 100% of the maximum speed.

**Reference Position / Photo Offset (C10):**

When the drive reaches it's reference position (defined by proximity switch or index pulse), the position counter will be loaded with this register value. In mode 4, this register sets an Offset to the position of the print mark (= distance between photocell and desired stop position)

**Reference Speed (C11):**

Setting range 0,1 % to 999,9 % of the maximum speed. The drive will always use this speed to execute a referencing command until it reaches the datum position.

**Reference Ramp (C12):**

Ramp time for execution of all referencing commands. Setting range 0,025....12.800 sec.

**Reference Mode (C13):**

There are 7 modes selectable, permitting the user to choose the propitiate procedure for definition of the datum position (not valid for mode 4).

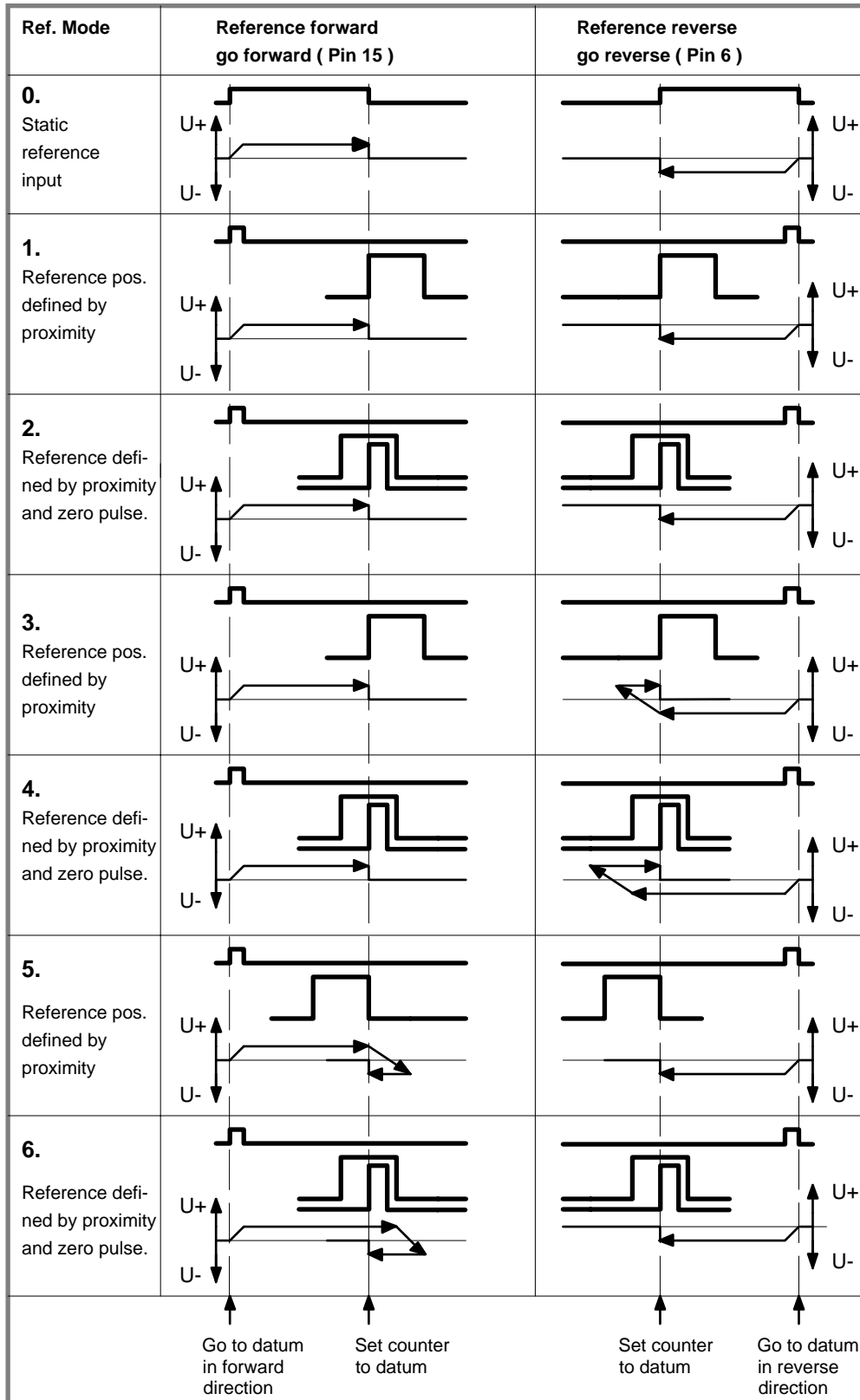

Fig. 8

### 3.1 Position – Settings

#### Pos. 1 - Pos. 8 (C14 – C21):

Registers to preset up to 8 fixed positions and to set branch and jump functions for the next target position.

When used as a position register, the setting range is -9,999,999...0...+9,999,999. The high order position represents the sign, which can be cycled to "+", "-" and "#". When set to "+" or "-", the subsequent digits will be a position value. When set to "#", the subsequent digits will be a branch address and the adjusting range will be automatically limited to 01 - 08.

When, in the logical sequence of positions, the unit finds a branch instructions, the next position to go will be the one defined by the number after the "#" branch character. The starting position is defined by your setting of the pointer.

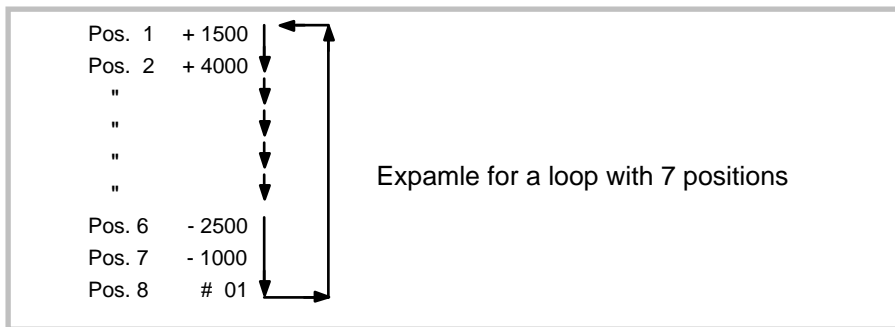

Fig. 9

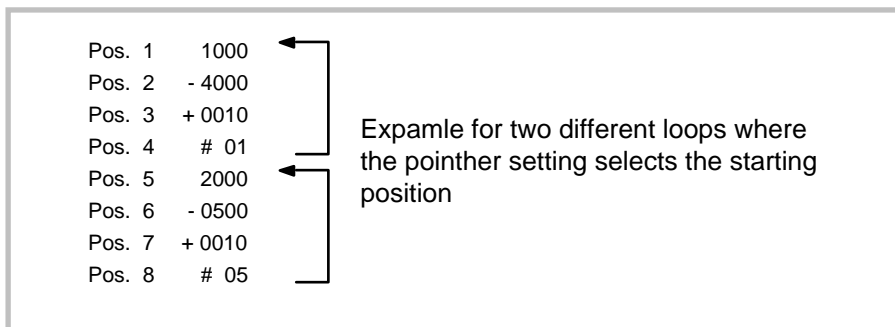

Fig. 10

### 3.2 Set Up – Settings

#### Encoder Direction (C46):

Can be set to „0“ or „1“ only. Determines the direction of counting of the encoder.

#### Offset (C47):

Digital setting of analogue offset. Setting range +/- 999. Normal setting "0".

**Remark:** PS125 uses precision instrumental amplifiers which do not need an offset adjustment. In larger drive plants however, by balance currents between several devices, an external offset can build up, which can be compensated by the offset adjust. Also, offset setting can be used to compensate for deadband with AC inverter drives

#### Gain Correction (C48):

Digital setting of gain control (proportional control)

Range 0 - 9999. Setting to 9999 results in a response of 100 mV per error bit. Recommended setting: 200...2000 ( i. e. 2mV...20mV per error bit).

#### Gain Total (C50):

Digital setting of the analogue output voltage for the positioning speed. Range 0 - 99999. Setting of 900 = 9.00 Volts of output voltage at 100.0% speed preset.

**Unit-Number (C90):**

Allows entry of a device address between 11 and 99. It is not allowed to use addresses containing a "0" (i.e. 20, 30, 40 etc.) as these are reserved for collective addressing of several units. Factory setting: 11.

**Baud-Rate (C91):**

The following transmission rates can be selected:

0	9600 Baud
1	4800 Baud
2	2400 Baud
3	1200 Baud
4	600 Baud
5	19200 Baud
6	38400 Baud

Fig. 11

Factory setting: 0

**Serial Format (C92):**

The following formats of serial data can be selected:

Ser-Form	Databits	Parity	Stopbits
0	7	Even	1
1	7	Even	2
2	7	Odd	1
3	7	Odd	2
4	7	None	1
5	7	None	2
6	8	Even	1
7	8	Odd	1
8	8	None	1
9	8	None	2

Fig. 12

Factory setting: 0

#### 4. The Serial Interface

The interface includes a RS 232 interface. As an option, an additional RS 485 interface is available which can be set to 2-wire or to 4-wire operation.

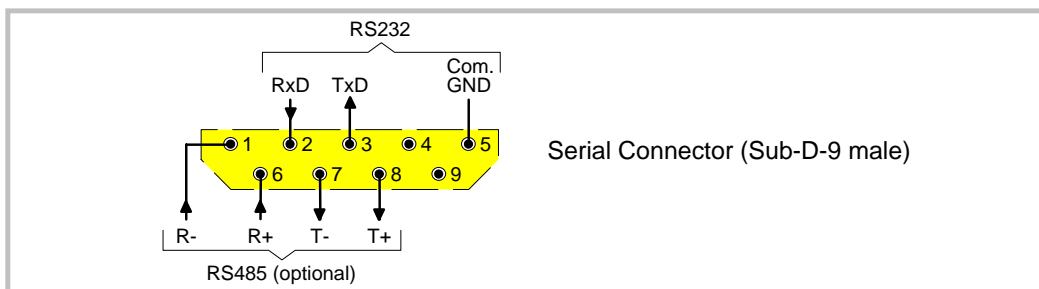

Fig. 13

In general, for commissioning a PC with RS 232 link will be used. For later changes of operator data, either the RS 232 link (1 axis only) or the RS 485 link (up to 32 axis) can be used. Register „Serial Mode“ allows to set the desired communication.

#### 4.1 RS232

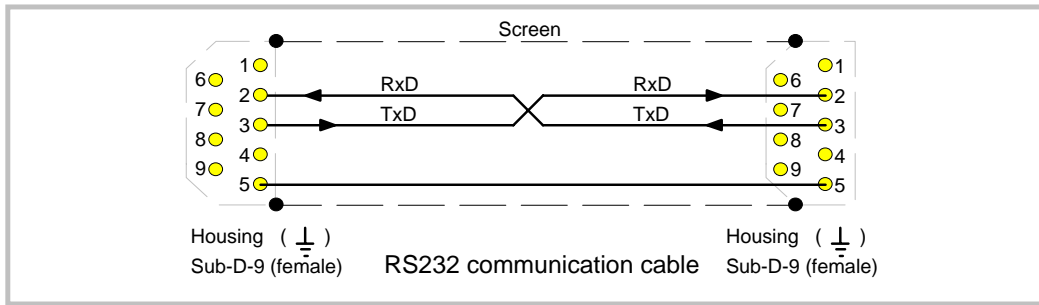

Fig. 14

It is important, with use of a RS232 cable, that only the connector pins 2, 3 and 5 are used and all other pins are unconnected!

#### 4.2 RS485 - 2 Wire

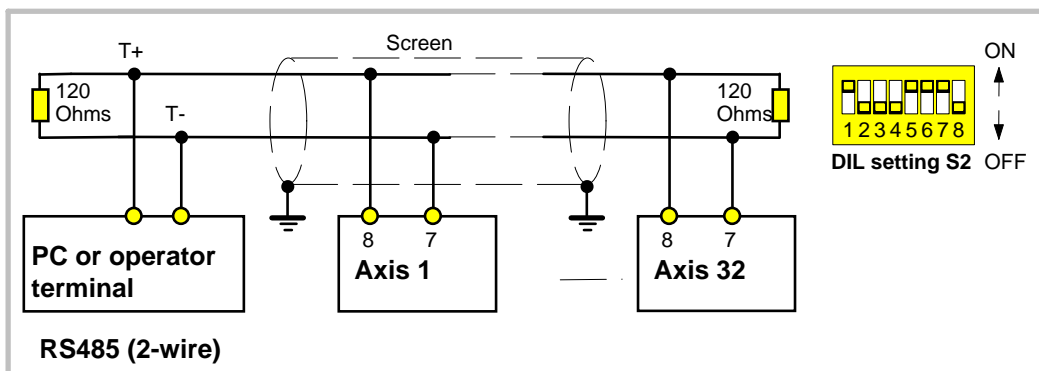

Fig. 15

#### 4.3 RS485 - 4 Wire

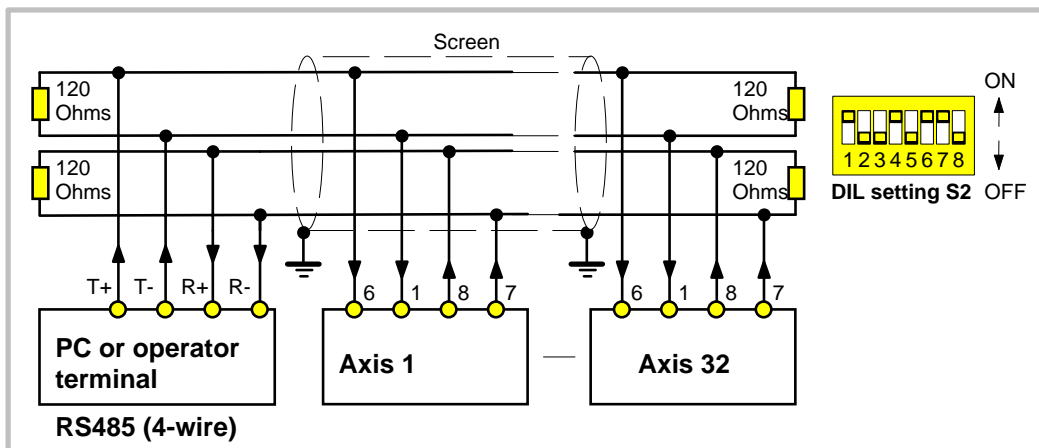

Fig. 16

## 5. Overview Parameter Setting

Parameter	Units	Format	Serial Code	Minimum	Maximum	Default
Incremental Length	Length Units	xxxxxxx	00	1	9999999	1000
Position Number	-	x	01	1	8	1
Mode	-	x	02	0	3	0
Accel Ramp to 100%	Sec.	xx.xxx	03	0.025	12.800	1.000
Decel Ramp from 100%	Sec.	xx.xxx	04	0.025	12.800	1.000
Emergency Ramp	Sec.	xx.xxx	05	0.000	12.800	0.100
Pulse per 1000	Impulse	xxxxxxx	06	1	9999999	10000
Position Window	Length Units	xxx	07	1	999	25
Frequency at 100%	Hz	xxxxxx	08	1	300000	100000
Speed Adjust	%	xxx.x	09	0.1	999.9	100.0
Reference Position/ Photo Offset	Length Units	+/- xxxxxxx	10	- 9999999	+ 9999999	0
Reference Speed	%	xxx.x	11	0.1	999.9	10.0
Reference Ramp	Sec.	xx.xxx	12	0.025	12.800	1.000
Reference Mode	-	x	13	0	6	1
Position 1	Length Units or Position Number	+/- xxxxxxx # xx	14	- 9999999 # 01	+ 9999999 # 8	10000
Position 2	Length Units or Position Number	+/- xxxxxxx # xx	15	- 9999999 # 01	+ 9999999 # 8	20000
↓	↓	↓	↓	↓	↓	↓
Position 7	Length Units or Position Number	+/- xxxxxxx # xx	20	- 9999999 # 01	+ 9999999 # 8	70000
Position 8	Length Units or Position Number	+/- xxxxxxx # xx	21	- 9999999 # 01	+ 9999999 # 8	80000
Encoder Direction	-	x	46	0	1	0
Offset	-	+/- xxx	47	- 999	+ 999	0
Gain Correction	-	xxxx	48	0	9999	200
Gain Total	-	xxxxx	50	0	99999	1000
Unit Number	-	xx	90	11	99	11
Serial Baud Rate	-	x	91	0	6	0
Serial Format	-	x	92	0	9	0

## 6. Overview Commands

Command	Serial Code	Control Word	Hardware Command	Serial Command	
Reset	60	H'0080	No	Yes	Static
Start	61	H'0040	Pin 8	Yes	Rising Edge
Go forward (Ref. / Jog)	62	H'0020	Pin 15	Yes	Rising Edge / Static
Go reverse (Ref. / Jog)	63	H'0010	Pin 6	Yes	Rising Edge / Static
Emergency Stop	64	H'0008	Pin 14	Yes	Static
Set to Jog	65	H'0004	Pin 7	Yes	Static
Reference Proximity/ Print mark input	66	H'0002	Pin 13	Yes	Rising Edge / Falling Edge
Activate Data	67	H'1000	No	Yes	Rising Edge
Store EEPROM	68	H'0001	No	Yes	Rising Edge
Start Testprogramm	69	H'2000	No	Yes	Static

## 7. Overview Variables

Serial Code	Description	Scaling
:0	Counter for motrona tests only	
:1	Actual positional error	Encoder increments
:2	Actual speed reference output	0 = max.rev. 2048 = standstill 4095 = max. forw.
:3	Actual position	Encoder increments
:4	Target position	Encoder increments
:5	Distance to move to new target position (Gesamtweg)	Encoder increments
:6	Accelerating distance	Encoder increments
:7	Deceleration distance	Encoder increments
:8	End position for acceleration ramp	Encoder increments
:9	Start position for deceleration ramp	Encoder increments
:0	Time for positioning	msec.
:1	Time to move with maximum speed.	msec.
:2		
:3		
:4		
:5		
:6		
:7	Position window	Encoder increments
:8	Reference position	Encoder increments
:9	Maximum positioning speed	0 = max.rev. 2048 = standstill 4095 = max. forw.

## 8. Operator Surface OS 3.0

File Comms Tools

**PARAMETERS**

Data-Setting	
<b>Incremental Length</b>	<b>0100000</b>
Position Number	04
Mode	3
Accel Ramp to 100%	00.500
Decel Ramp from 100%	00.500
Emergency Ramp	00.100
Pulse per 1000	0001000
Position Window	010
Frequency at 100%	089955
Speed Adjust %	100.0
Reference Position	+0000000
Ref. Speed %	005.0
Reference Ramp	00.500
Reference Mode	4
Position-Setting	
Position 1	+0020000
Position 2	+0080000
Position 3	+0160000
Position 4	-0090000
Position 5	-0080000
Position 6	-0020000
Position 7	+0000000
Position 8	#0000001

**INPUTS**

	serial	external
Reset	<input type="checkbox"/>	
Start	<input type="checkbox"/>	<input type="checkbox"/>
go forward	<input type="checkbox"/>	<input type="checkbox"/>
go reverse	<input type="checkbox"/>	<input type="checkbox"/>
Emergency Stop	<input type="checkbox"/>	<input type="checkbox"/>
set to Jog	<input type="checkbox"/>	<input type="checkbox"/>
Reference Proximity	<input type="checkbox"/>	<input type="checkbox"/>
Activate Data	<input type="checkbox"/>	
Store EEPROM	<input type="checkbox"/>	

**OUTPUTS**

Ready

Moving

in Position

Datum done

**CONTROLS**

Read

Transmit

Transmit All

Store EEPROM

Reset OFF

**DIFFERENTIAL COUNTER**

0

- 56 0 + 56

**OS SERIAL SETTINGS**

Unit Nr.: 11 - COM: 1 - 9600, 7, 1, E

File Comms Tools

**PARAMETERS**

Frequency at 100%	
Speed Adjust %	100.0
Reference Position	+0000000
Ref. Speed %	005.0
Reference Ramp	00.500
Reference Mode	4
Position-Setting	
Position 1	+0020000
Position 2	+0080000
Position 3	+0160000
Position 4	-0090000
Position 5	-0080000
Position 6	-0020000
Position 7	+0000000
Position 8	#0000001
Set-Up-Setting	
Encoder Direction	0
Offset	+010
Gain Correction	0750
Gain Total	00300
Unit Number	11
Serial Baud Rate	0
<b>Serial Format</b>	<b>0</b>

**INPUTS**

	serial	external
Reset	<input type="checkbox"/>	
Start	<input type="checkbox"/>	<input type="checkbox"/>
go forward	<input type="checkbox"/>	<input type="checkbox"/>
go reverse	<input type="checkbox"/>	<input type="checkbox"/>
Emergency Stop	<input type="checkbox"/>	<input type="checkbox"/>
set to Jog	<input type="checkbox"/>	<input type="checkbox"/>
Reference Proximity	<input type="checkbox"/>	<input type="checkbox"/>
Activate Data	<input type="checkbox"/>	
Store EEPROM	<input type="checkbox"/>	

**OUTPUTS**

Ready

Moving

in Position

Datum done

**CONTROLS**

Read

Transmit

Transmit All

Store EEPROM

Reset OFF

**DIFFERENTIAL COUNTER**

0

- 56 0 + 56

**OS SERIAL SETTINGS**

Unit Nr.: 11 - COM: 1 - 9600, 7, 1, E

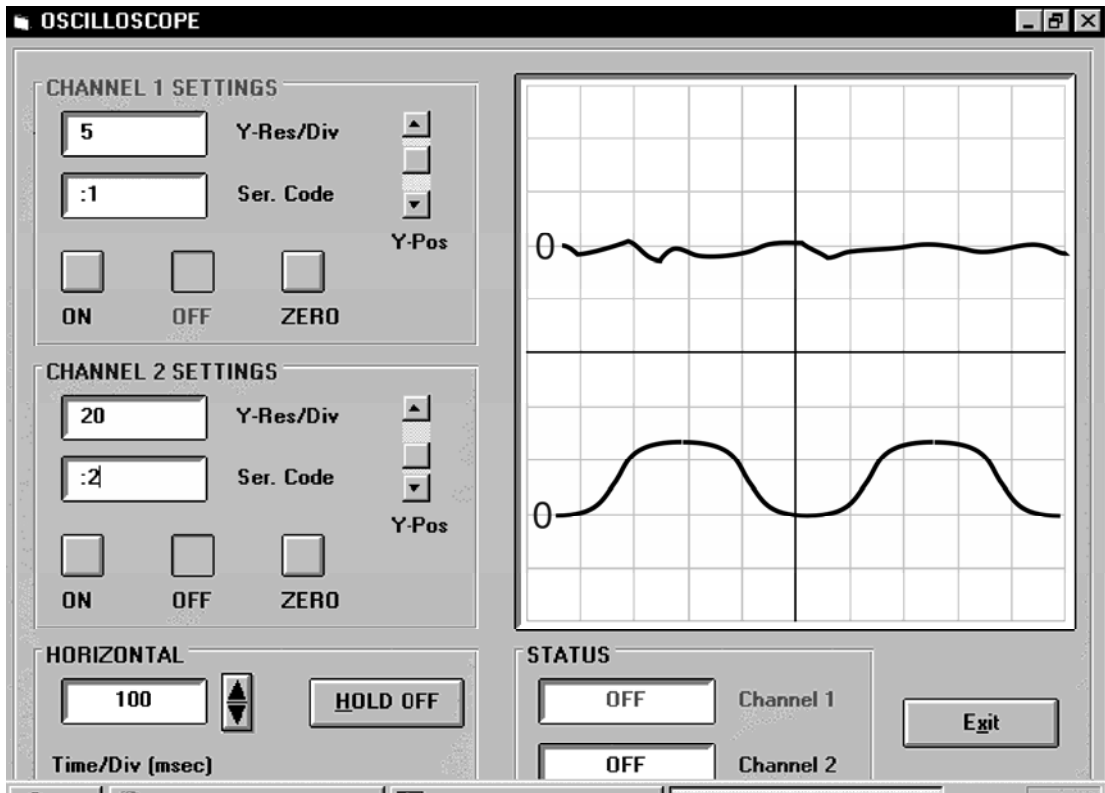
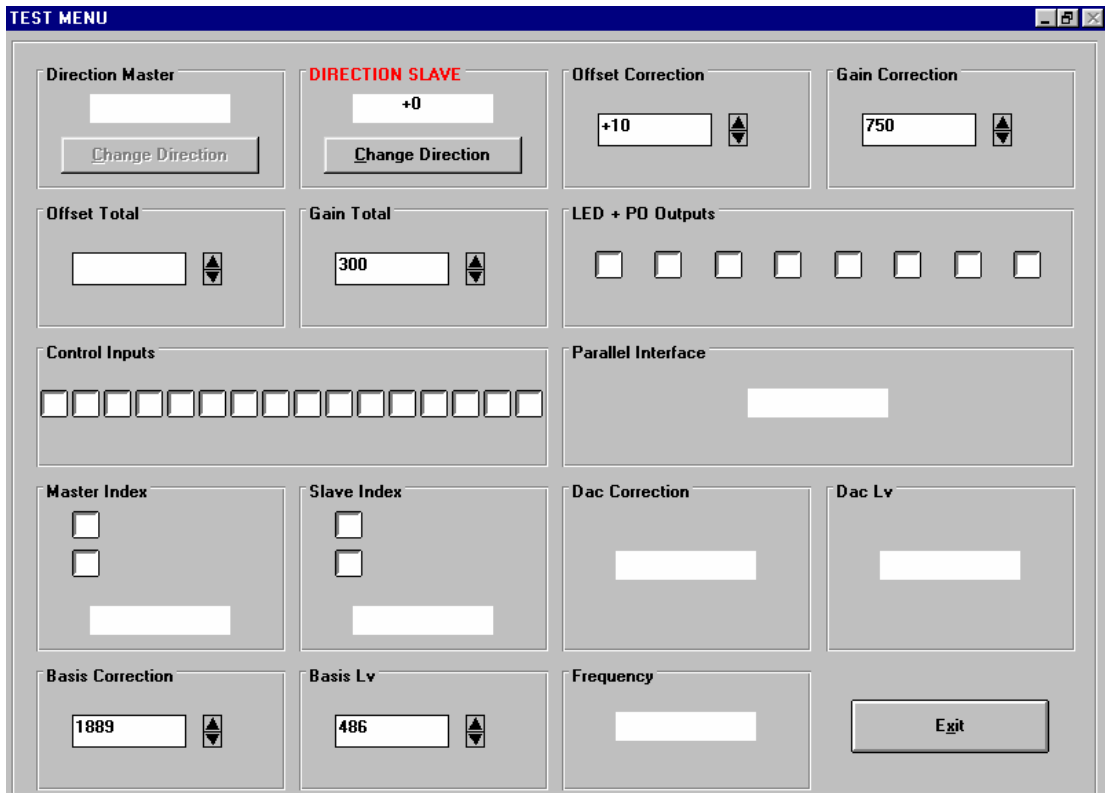

## 9. Steps for Commissioning

- 9.1 When you have started the OS3.0 operator software and the PS125 controller is online, you will find the screen like shown in section 8.
- 9.2 Enter all variables according to need. During setup, the unit will use the Reference speed and the Reference Ramp to move the drive, therefore set the percentage to a propriate value (i.e. 20.0%) with an acceptable ramp time. Set the Gain Total to the maximum analogue output you need for full speed (i.e. set 900 to receive 9.00 Volts at 100% speed setting). You should not set 10 Volts, because the controller needs some span to make corrections. Set Gain Correction to a value like 300 first.
- 9.3 Click to "Tools" and select the "Test Menü". The Test screen appears like shown in section 8. Click to the "Direction Slave" box. The drive will now ramp up using the "Reference" settings. Observe the counter in the box. This counter must count up (increment). Where you find we count down, click to the "Change direction" button. When we count up, click tot the "Frequency" box
- 9.4 After clicking to the "Frequency" box, the drive will first ramp down from reference speed to standstill and then **immediately ramp up to maximum speed**, using your ramp settings. After approximately 10 seconds, the encoder feedback frequency at maximum speed appears in the frequency box.
- 9.5 Click ""Exit" now. This will automatically store the direction bit and the maximum frequency to the corresponding registers and the EEPROM of the unit. The drive will ramp down to the standstill and the TEST screen will close.
- 9.6 You should verify that the unit detects all of your remote signals like "Start" or "Proximity". Watch the indicator boxes in the "external" column of the INPUTS field while you switch the external signals ON and OFF.
- 9.7 We are now for our first positioning trials. While we move from one position to next, try to increase the ""Gain-Correction" setting. The rule is to use a setting **as high as possible** (example 1000 or even 2000). But we could reach a stability threshold where the drive starts to move roughly or to make oscillation. Then reduce "Gain Correction" until we are in the stable range again.

This concludes the steps for commissioning. It could be useful to select the oscilloscope function in the tools menu for visual impression of the positioning procedure.

Section 7. shown a list of variables that you can display on the scope screen. When, i.e., you set the serial code to ":2", the scope will show you the speed profile of your drive.

## 10. Specifications and Dimensions

Power supply	:	18...30 V unstabilised
Consumption	:	approx. 200 mA ( plus 25 % of the encoder supply current, if internal encoder supply used )
Encoder Supply	:	Aux. voltage 5,5 V, max. 500 mA installed
Processor	:	H8 / 325 with 20 MHz clock frequency
PBC and Technology	:	SMD, Multiplayer PCB`s, High speed logic 74 HCT
Encoder Inputs	:	A, $\bar{A}$ , B, $\bar{B}$ , Z, $\bar{Z}$ ( 5 V TTL / RS 422 )
Other Inputs	:	6 control lines, all PNP with 18 - 30 V level
Serial link	:	RS 232 , optional RS 485
Absolute max. frequency	:	80 kHz
Response time	:	approx. 500 $\mu$ sec

- Analogue output:                   + / - 10 V ( I max = 5 mA )  
Resolution: 12 Bit ( = 4096 steps )
- Analogue Correction       : 10 Bit = 1024 error increments  
(Saturation)
- Error memory                 : 32 000 error increments
- Control Outputs            : 4 transistor outputs ( opto- coupler 50 V / 70 mA max )
- Operating temperature    : 0...45° C
- Dimensions                 : see drawing
- Weight                      : approx. 850 g

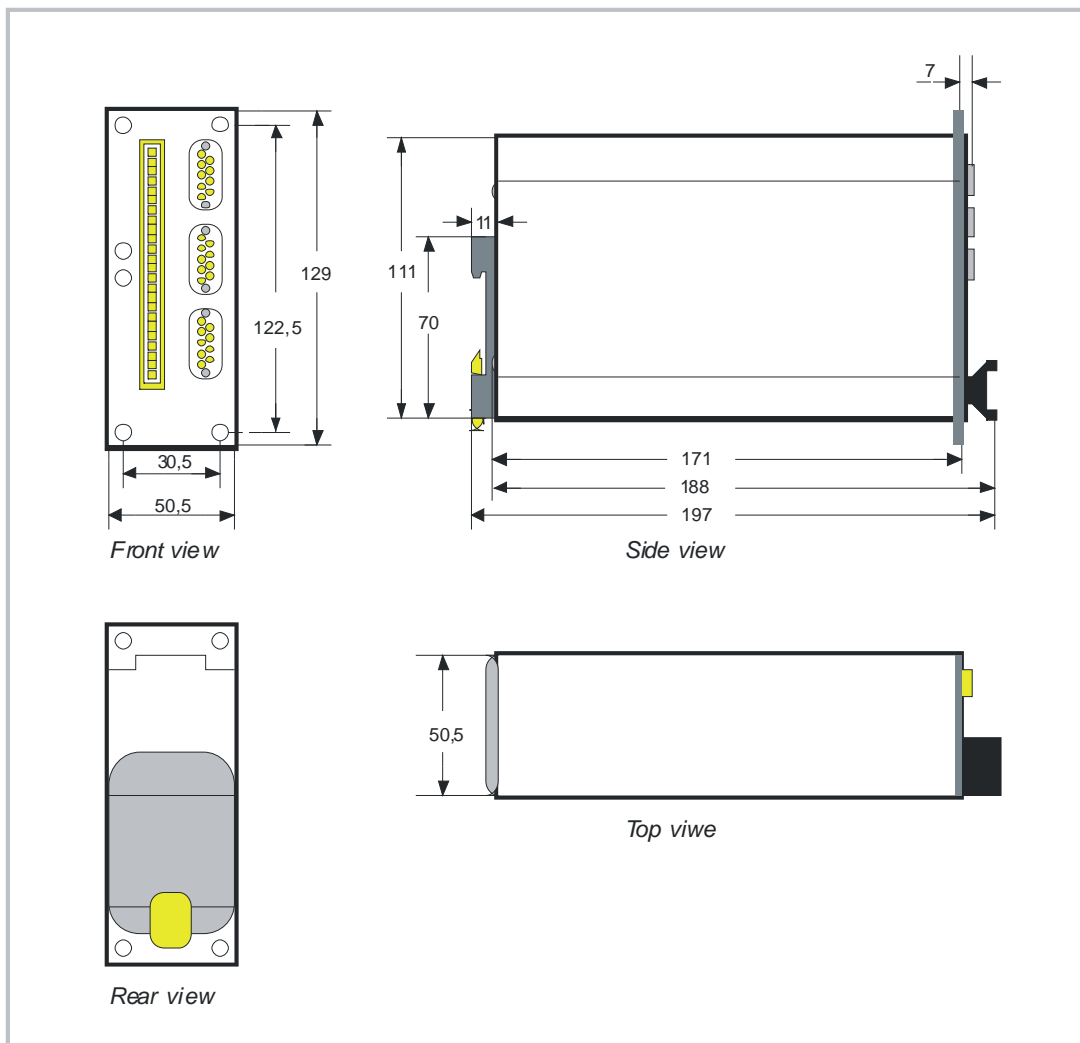

These instructions have been written and checked to the best of our knowledge and belief.  
However, **motrona** will not be liable for errors and reserves the right for changes at any time without notice.